

Appalachian 54-49C



DAEPUMPS.COM

info@daepumps.com

(760) 821-8112

PUMP SPECIFICATIONS



Pump End: DAE Pumps MCL-P1458C
Pump Size: 5x4 inches (125x100 mm)
Max Flow: 1300 US GPM (305 m³/h)
Max Head: 160 feet (49 m)
Solids Size: 1 inches (25.4 mm)
Mechanical Seal: Single mechanical seal 1.875"
Lip Seals: CR type, single lip, Buna-N (Bearing & SAE Cover) and Viton(Stuffing box)
Non-Drive End Bearing: Single row ball bearing 6310
Drive End Bearing: Single row ball bearing 6410
Air/Water Chamber: Steel material and designed to separate air and water before entering into vacuum pump suction hose.
Discharge Non Return Valve: Swing type, cast iron with Buna-N disc (Viton optional)
Gasket: Aramid Fiber w/ EPDM
O Ring: Buna-N

VACUUM ASSISTED PRIMING SYSTEM

INSTANT-PRIME® SYSTEM: Patent Pending self priming pumps are equipped with the most powerful priming system and P-S-P mechanism. Instant-Prime® pump sets a new benchmark of vacuum assisted priming pumps in the industry.

VACUUM PUMP DATA*: Air Capacity: 112CFM
Vacuum: -26inHg(9m)

* at engine speed 2200 rpm

PUMP FEATURES

ECO Friendly Vacuum Priming System

DAE Pumps' EVP self priming system has extraordinary features like large air process capability, high vacuum, low operation temperature, maintenance free, oil and mechanical seal free etc.

P-S-P Auto Switch System (Prime-Sleep-Prime)

EVP system will be switched to sleep status automatically once priming was finished. When it is used for general purpose application, EVP system only operates for a few seconds for priming, which makes it almost unnecessary for daily maintenance or changing spare parts within its life cycle.

Dry Running Protection System

Instant-Prime® pumps offer three types of dry running seal options: oil reservoir lubricated mechanical seal, air cushion protected mechanical seal and grease lubricated lip seals configurations. Either of them can secure the pump run dry for a long time.

Cooling System**

A pressurized cooling flush water is introduced from centrifugal pump into vacuum pump's water jacket and then flows back to centrifugal pump. This cooling system cools the vacuum pump quickly and brings most of the heat out of the vacuum pump's cavity, and makes its rotor has an extraordinary long life.

Easy Maintenance Structure

It is very convenient to remove the vacuum pump's cover from its non-drive end, and slides can be easily pulled out for inspection or replacement. It is also easy to access to the centrifugal pump's impeller, wear ring or mechanical seal for inspection or maintenance without removing diesel engine or pump's frame since the centrifugal pump's suction cover can be fully opened.

All-In-One Pump Applications

EVP Priming system's powerful function makes Instant-Prime® pumps can be used in almost all aspects of fluid industry, including well point dewatering. Buy one pump and get all your jobs covered.

** cooling system is only needed for well point dewatering application.

APPALACHIAN 54-49C PERFORMANCE CURVE

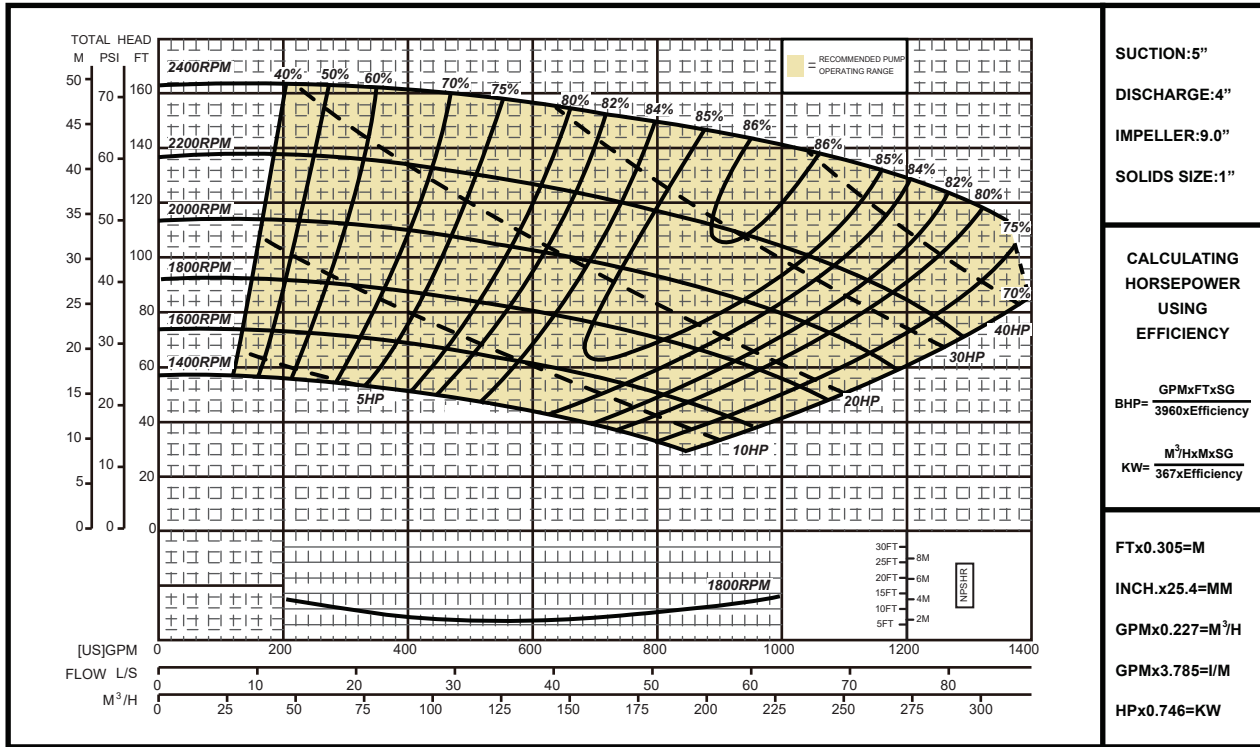

PUMP MATERIAL OF CONSTRUCTION

Main Parts	Standard (code:38)	Optional 1 (code:58)	Optional 2 (code:88)	Optional 3 (code:98)
Impeller	CA6NMSS	CA6NMSS	26% High Chrome	CD4MCu
Shaft	17-4PH	17-4PH	17-4PH	17-4PH
Wear Ring	Gray Iron	Gray Iron	Carbon Steel	316SS
Suction Cover	Gray Iron	Ductile Iron	26% High Chrome	CD4MCu
Volute	Gray Iron	Ductile Iron	26% High Chrome	CD4MCu
Stuffing Box	Gray Iron	Ductile Iron	26% High Chrome	CD4MCu
Adaptor	Ductile Iron	Ductile Iron	Ductile Iron	Ductile Iron

ENGINE SPECIFICATIONS

Engine Model: Cummins QSF2.8
 Rated Power At Speed: 49 HP @ 2500 RPM
 Engine Type: Turbocharged Charge Air Cooled and EGR turbocharging and optionally with and without charge air cooling.
 Displacement: 171 Cu.In. (2.8 Liters)
 EPA Tier: Tier 4 Final/Stage III
 Fuel Tank: 65 U.S.Gallons (245 Liters)
 Full Load Operating Time: 26.3 Hours
 Starter: 12 Volts Electric
 Control Panel: Murphy, Controls Inc, Deepsea, Kensho, Lofa

	Engine Performance Data Cummins Inc Columbus, Indiana 47202-3005 http://www.cummins.com	Industrial QSF2.8 FR94165	37 kW (49 hp) @ 2500 RPM 200 N-m (148 lb-ft) @ 1600 RPM
			Configuration: D0E3006CX03 CPL Code: 44237 Revision: 10-Jul-2023

Compression Ratio: 16.9:1	Displacement: 2.8 L (171 in 3)
Fuel System: Bosch HPCR	Aspiration: Turbocharged Charge Air Cooled and EGR

Emission Certification

EPA/CARB Tier 4(f), EU Stage IIIB

Rating Types

Intermittent

All data is based upon the engine operating with fuel system, water pump, and with inlet restriction and exhaust restriction at or below datasheet limits. The alternator, fan, optional equipment, and driven components are not included. Coolant flows and heat rejection data is based on a coolant mixture of 50% ethylene glycol and 50% water.

All data is subject to change without notice.

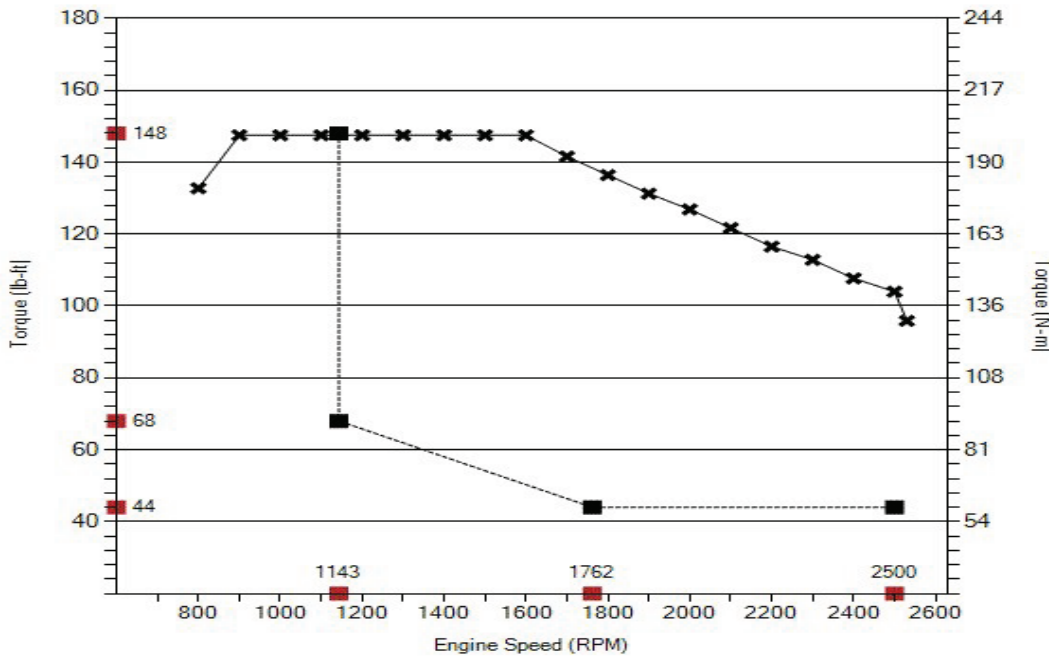

Torque Curve with NTE Zone (CEB00346)		
91.44 m (300 ft)		
RPM	lb-ft	N-m
800	133	180
900	148	200
1000	148	200
1100	148	200
1200	148	200
1300	148	200
1400	148	200
1500	148	200
1600	148	200
1700	142	192
1800	136	185
1900	131	178
2000	127	172
2100	122	165
2200	117	158
2300	113	153
2400	108	146
2500	104	141
2530	96	130

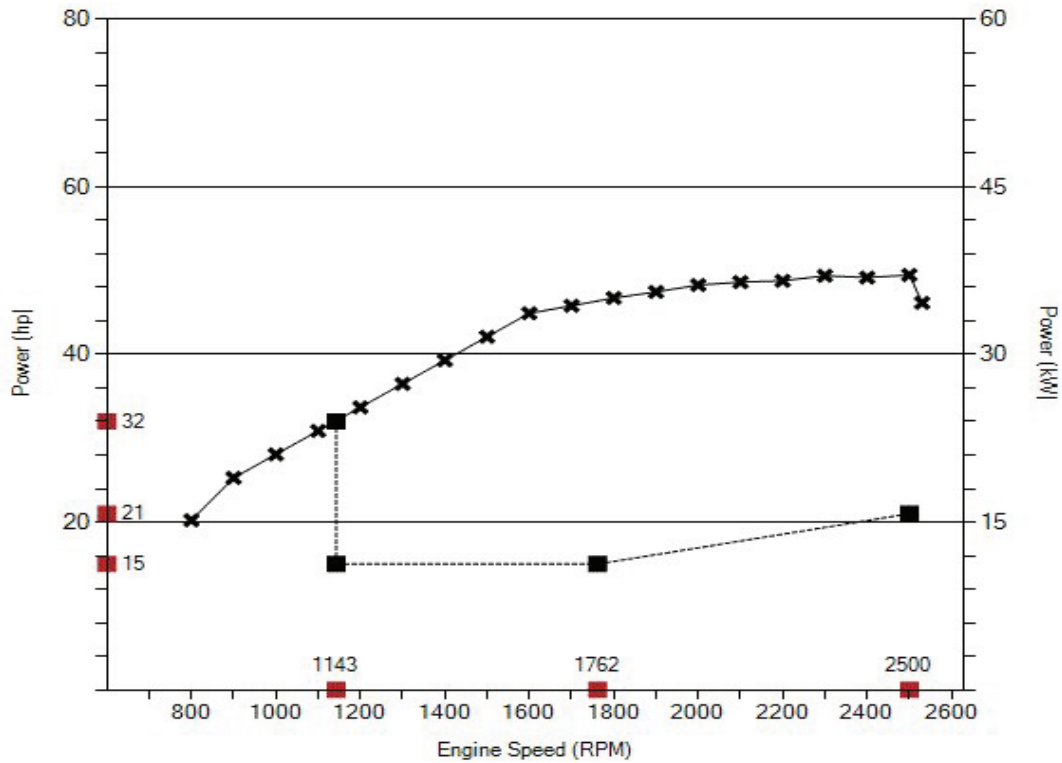

Power Curve with NTE Zone (CEB00346)		
91.44 m (300 ft)		
RPM	hp	kW
800	20	15
900	25	19
1000	28	21
1100	31	23
1200	34	25
1300	37	27
1400	39	29
1500	42	31
1600	45	34
1700	46	34
1800	47	35
1900	47	35
2000	48	36
2100	49	36
2200	49	36
2300	49	37
2400	49	37
2500	50	37
2530	46	34

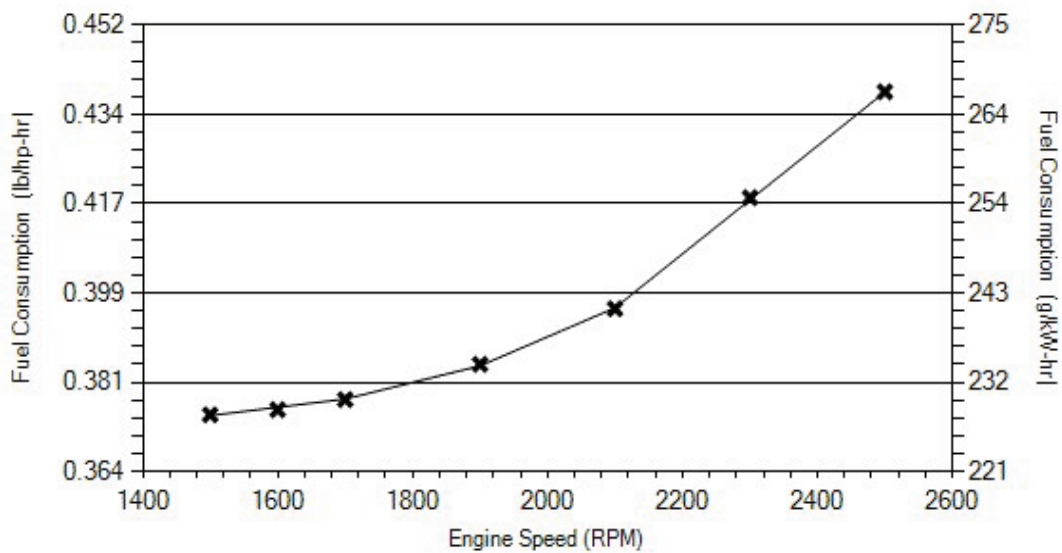

Fuel Consumption		
RPM	lb/hp-hr	g/kW-hr
1500	0.375	228
1600	0.376	229
1700	0.378	230
1900	0.385	234
2100	0.396	241
2300	0.418	254
2500	0.439	267

Curves shown above represent gross engine performance capabilities obtained and corrected in accordance with SAE J1995 conditions of 100 kPa barometric pressure [91 m (300 ft) altitude], 25 deg C (77 deg F) inlet air temperature, and 1 kPa water vapor pressure with No. 2 diesel fuel.

Tolerance within +/- 5%

Intake Air System

Maximum allowable air temperature rise over ambient at intake manifold (naturally aspirated engines) or turbo compressor inlet (turbo-charged engines): *This parameter impacts emissions, LAT, and/or altitude capability

27.0 delta deg F 15.0 delta deg C

Cooling System

Maximum charge air cooler outlet to ambient at 25 deg C (77 deg F) (CAC dT)

113.4 delta deg F 63.0 delta deg C

Maximum allowable pressure drop across charge air cooler and OEM CAC piping (IMPD)

4.0 in-Hg 13.5 kPa

Maximum coolant temperature for engine protection controls

225 deg F 107 deg C

Maximum coolant operating temperature at engine outlet (max. top tank temp)

225 deg F 107 deg C

Exhaust System

Maximum exhaust backpressure imposed by exhaust system (if DPF is present, the limit is at soot level after regeneration or cleaning)

3.0 in-Hg 10.1 kPa

Recommended exhaust pipe size (inner diameter)

3.0 in 76 mm

Lubrication System

Nominal operating oil pressure at minimum low idle

25.5 psi 176 kPa

Nominal operating oil pressure at maximum rated speed

47.9 psi 330 kPa

Minimum engine oil pressure at minimum low idle (for engine protection devices)

7.5 psi 52 kPa

Fuel System

*Fuel cooling requirements with diesel fuel

The maximum heat rejection to return fuel at maximum coolant and inlet fuel temperature is of 80 kg/hr (176 lb/hr) with a fuel return temperature of 55 deg C (130 deg F) prior to cooler.

0.79 kW (45 BTU/min) at a fuel return flow rate

Maximum supply fuel flow

197 lb/hr 90 kg/hr

Maximum return fuel flow

176 lb/hr 80 kg/hr

Engine fuel compatibility (consult Service Bulletin #5411406 for appropriate use of other fuels)

B20, ULSD

Maximum fuel inlet pressure

2 psi 14 kPa

Performance Data

Maximum low idle speed: 1200 RPM

Minimum low idle speed: 700 RPM

Minimum engine speed for full load sustained operation: 1700 RPM

Maximum overspeed capability: 3100 RPM

Maximum continuous power: 47 kW (62 hp)

Maximum continuous speed: 2250 RPM

	Governed Power	Maximum Power	Peak Torque
Engine Speed	2500 RPM		1600 RPM
Output Power	37 kW (49 hp)		33 kW (45 hp)
Torque	141 N-m (104 lb-ft)		200 N-m (148 lb-ft)
Motoring Power	13 kW (18 hp)		6 kW (9 hp)
Intake Manifold Pressure	73 kPa (21 in-Hg)		47 kPa (14 in-Hg)
Turbo Comp. Outlet Pressure	85.9 kPa (25.4 in-Hg)		51.6 kPa (15.3 in-Hg)
Turbo Comp. Outlet Temperature	106 deg C (224 deg F)		78 deg C (173 deg F)
Inlet Air Flow	74 L/s (157 ft3/min)		42 L/s (90 ft3/min)
Charge (Fresh Air) Flow	5.3 kg/min (11.7 lb/min)		3.0 kg/min (6.6 lb/min)
Exhaust Gas Flow	153 L/s (324 ft3/min)		100 L/s (211 ft3/min)
Exhaust Gas Temperature	382 deg C (719 deg F)		434 deg C (813 deg F)
Maximum Fuel Flow to Pump	89.4 kg/hr (197 lb/hr)		7.8 kg/hr (17 lb/hr)
Heat Rejection to Coolant	32.1 kW (1828 BTU/min)		23.3 kW (1325 BTU/min)
Heat Rejection to Fuel	0.8 kW (45 BTU/min)		0.4 kW (22 BTU/min)
Heat Rejection to Ambient	9.1 kW (519 BTU/min)		8.3 kW (473 BTU/min)
Heat Rejection to Exhaust	34.3 kW (1952 BTU/min)		24.3 kW (1379 BTU/min)

*When operating Naturally Aspirated engines above SAE J1995 conditions, it should be noted that smoke levels will increase due to combustion inefficiencies associated with a reduction in the air to fuel mixture.

Cranking System (Cold Starting Capability)

Minimum cranking speed: 120 RPM

Maximum OEM parasitic load at 10 deg F and minimum cranking speed with all required starting aids before over crank protection limits.

70 lb-ft

95 N-m

Required Starting Aids:

None

Minimum ambient temperature for unaided cold start at maximum OEM parasitic load

-0.0 deg F

-17.8 deg C

Minimum ambient temperature with grid heater only at maximum OEM parasitic load

-0 deg F

-18 deg C

Minimum ambient temperature with coolant and lube heater at maximum OEM parasitic load

-40 deg F

-40 deg C

Noise Emissions

Free field sound pressure level at 1 meter (3.28ft) at rated power (speed and load) per SAE J1074.

Top: 90.7 dB(A)

Right Side: 93.5 dB(A)

Left Side: 92.8 dB(A)

Front: 93.3 dB(A)

Extended Datasheets

1. 00084.18 Altitude Derate Curve Calculator - Industrial

Change Log

Date	Author	Description
07/25/2013	Tieg Laskowske	Alpha update
01/31/2013	Omar Al-Dimashki	Initial creation
09/19/2013	Tieg Laskowske	Datasheet is Design Review ready
12/13/2013	Tieg Laskowske	Updated estimated breakaway torque/maximum parasitic load
03/05/2014	Don L Herlitz	Updated Fuel and Performance per Yiping Zhuang
03/21/2014	Don L Herlitz	Move to Beta Measured Status - Paul Hartstim
03/26/2014	Don L Herlitz	Move to Beta Measured Status - Paul Hartstim
06/14/2015	Neha Deshmukh	Updated Cold Start Capability section
10/09/2015	Neha Deshmukh	Updated inlet air restriction with inner diameter value - Joshua H

Status for curves and data: Final-(Measured data)

Data shown is representative of engine performance. Engine to engine variability may cause deviation from reported values

Data updated by Joshua J Harris

Bending moment diagrams may be available on GCE under Engine Specific Topics

TRAILER MOUNTED

NET WEIGHT: 3681 LBS.(1670 KG.)
SHIPPING WEIGHT: 4122 LBS.(1870 KG.)

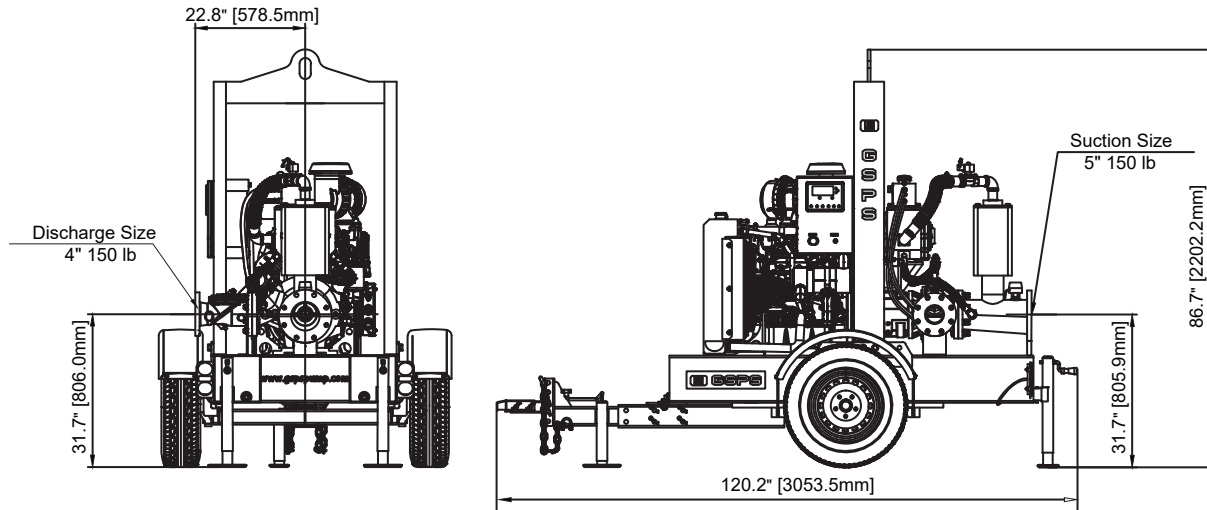

SKID MOUNTED

NET WEIGHT: 3505 LBS.(1590 KG.)
SHIPPING WEIGHT: 3946 LBS.(1790 KG.)

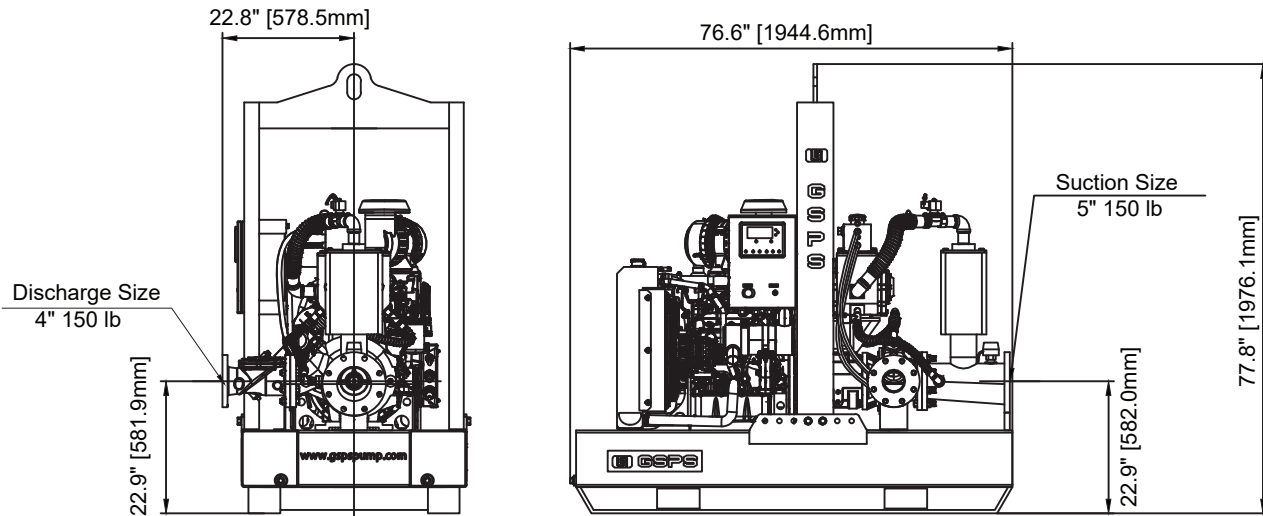

SOUND ATTENUATED

NET WEIGHT: 2727 LBS.(1237 KG.)
SHIPPING WEIGHT: 3057 LBS.(1387 KG.)

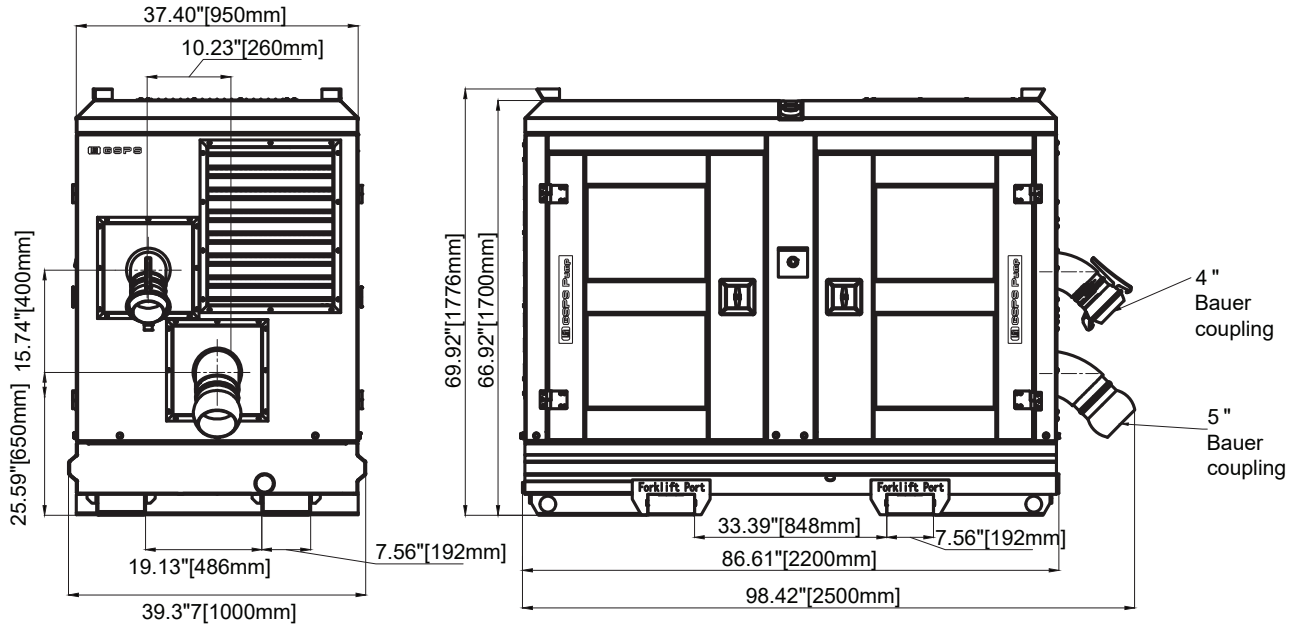

CONTACT US

 15405 Olde Highway 80
El Cajon, CA 92021

 (760) 821-8112

 www.daepumps.com

 info@daepumps.com