

Appalachian 65-250C



DAEPUMPS.COM

info@daepumps.com

(760) 821-8112

PUMP SPECIFICATIONS

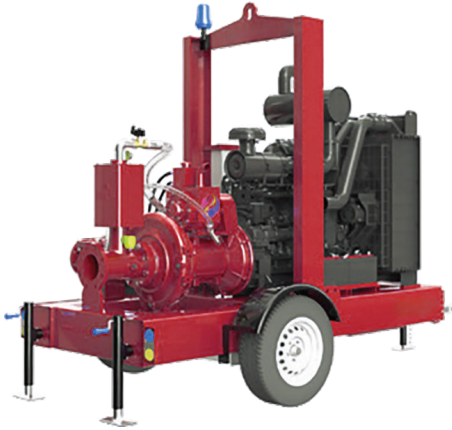

Pump End: DAE Pumps MCL-I5617C
Pump Size: 6x5 inches (150x125 mm)
Max Flow: 2290 US GPM (520 m³/h)
Max Head: 550 feet (168 m)
Solids Size: 0.8 inches (21 mm)
Mechanical Seal: Single mechanical seal 2.75"
Lip Seals: CR type, single lip, Buna-N (Bearing & SAE Cover) and Viton(Stuffing box)
Non-Drive End Bearing: Single row ball bearing 6314
Drive End Bearing: Duplex angular contact bearing 7316
Air/Water Chamber: Steel material and designed to separate air and water before entering into vacuum pump suction hose.
Discharge Non Return Valve: Swing type, cast iron with Buna-N disc (Viton optional)
Gasket: Aramid Fiber w/ EPDM
O Ring: Buna-N

VACUUM ASSISTED PRIMING SYSTEM

INSTANT-PRIME® SYSTEM: Patent Pending self priming pumps are equipped with the most powerful priming system and P-S-P mechanism. Instant-Prime® pump sets a new benchmark of vacuum assisted priming pumps in the industry.

VACUUM PUMP DATA*: Air Capacity: 112CFM
Vacuum: -26inHg(9m)

* at engine speed 2200 rpm

PUMP FEATURES

ECO Friendly Vacuum Priming System

DAE Pumps' EVP self priming system has extraordinary features like large air process capability, high vacuum, low operation temperature, maintenance free, oil and mechanical seal free etc.

P-S-P Auto Switch System (Prime-Sleep-Prime)

EVP system will be switched to sleep status automatically once priming was finished. When it is used for general purpose application, EVP system only operates for a few seconds for priming, which makes it almost unnecessary for daily maintenance or changing spare parts within its life cycle.

Dry Running Protection System

Instant-Prime® pumps offer three types of dry running seal options: oil reservoir lubricated mechanical seal, air cushion protected mechanical seal and grease lubricated lip seals configurations. Either of them can secure the pump run dry for a long time.

Cooling System**

A pressurized cooling flush water is introduced from centrifugal pump into vacuum pump's water jacket and then flows back to centrifugal pump. This cooling system cools the vacuum pump quickly and brings most of the heat out of the vacuum pump's cavity, and makes its rotor has an extraordinary long life.

Easy Maintenance Structure

It is very convenient to remove the vacuum pump's cover from its non-drive end, and slides can be easily pulled out for inspection or replacement. It is also easy to access to the centrifugal pump's impeller, wear ring or mechanical seal for inspection or maintenance without removing diesel engine or pump's frame since the centrifugal pump's suction cover can be fully opened.

All-In-One Pump Applications

EVP Priming system's powerful function makes Instant-Prime® pumps can be used in almost all aspects of fluid industry, including well point dewatering. Buy one pump and get all your jobs covered.

** cooling system is only needed for well point dewatering application.

APPALACHIAN 65-250C PERFORMANCE CURVE

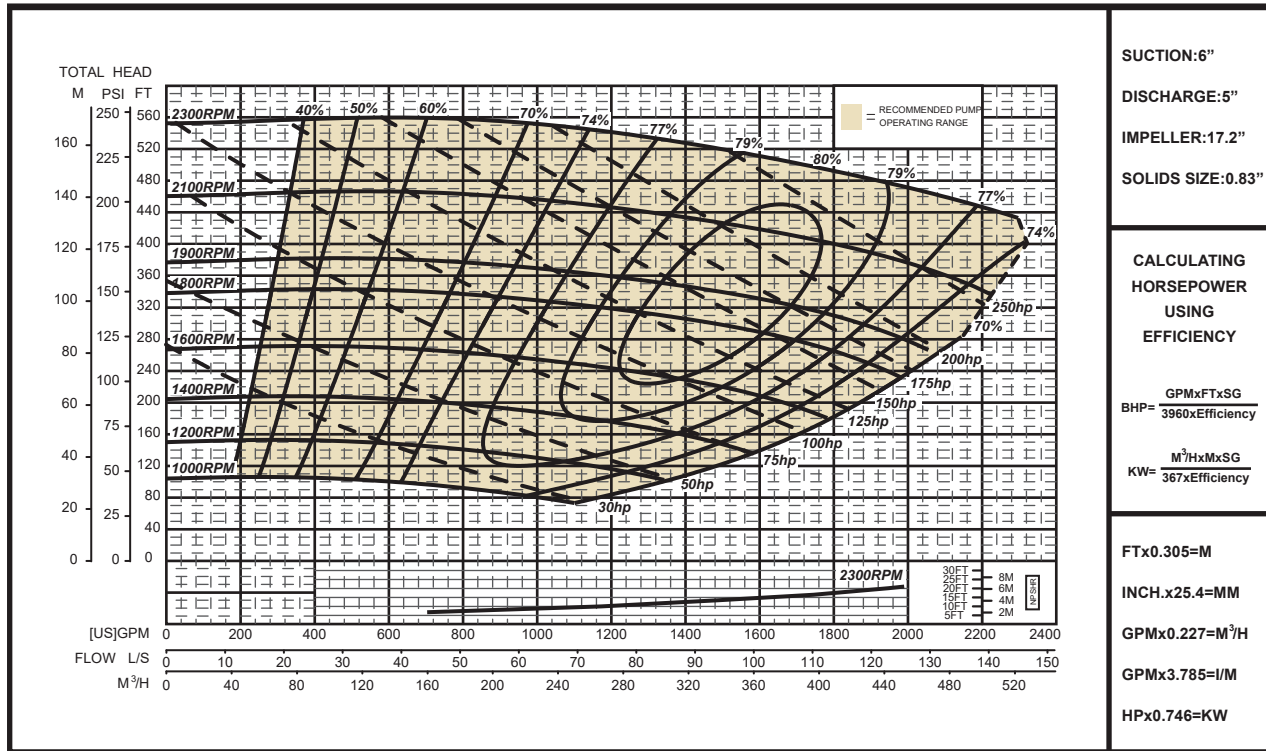

PUMP MATERIAL OF CONSTRUCTION

Main Parts	Standard (code:38)	Optional 1 (code:58)	Optional 2 (code:88)	Optional 3 (code:98)
Impeller	CA6NMSS	CA6NMSS	26% High Chrome	CD4MCu
Shaft	17-4PH	17-4PH	17-4PH	17-4PH
Wear Ring	Gray Iron	Gray Iron	Carbon Steel	316SS
Suction Cover	Gray Iron	Ductile Iron	26% High Chrome	CD4MCu
Volute	Gray Iron	Ductile Iron	26% High Chrome	CD4MCu
Stuffing Box	Gray Iron	Ductile Iron	26% High Chrome	CD4MCu
Adaptor	Ductile Iron	Ductile Iron	Ductile Iron	Ductile Iron

ENGINE SPECIFICATIONS

Engine Model: Cummins B6.7
 Rated Power At Speed: 250 HP @ 2000 RPM
 Engine Type: Turbocharged Charge Air Cooled
 Displacement: 408 Cu.In. (6.7 Liters)
 EPA Tier: Tier 4 Final/Stage V
 Fuel Tank: 102 U.S. Gallons (388 Litres) Larger volume fuel tank is available.
 Full Load Operating Time: 6.2 Hours
 Starter: 12 Volts Electric
 Control Panel: Murphy, Controls Inc, Deepsea, Kensho, Lofa

	Engine Performance Data Cummins Inc Columbus, Indiana 47202-3005 http://www.cummins.com	Industrial B6.7 FR95888	186 kW (250 hp) @ 2000 RPM 1152 N-m (850 lb-ft) @ 1500 RPM		
			Configuration D313032CX03	CPL Code 4834	Revision 10-Jul-2023

Compression Ratio: 17.3:1 Fuel System: Bosch HPCR	Displacement: 6.7 L (408 in3) Aspiration: Turbocharged Charge Air Cooled
--	---

Emission Certification

CARB Tier 4(f), EU Stage V, JMLIT T4f, KMOE Tier 4, US EPA Tier 4(f)

Rating Types

Intermittent

All data is based upon the engine operating with fuel system, water pump, and with inlet restriction and exhaust restriction at or below datasheet limits. The alternator, fan, optional equipment, and driven components are not included. Coolant flows and heat rejection data is based on a coolant mixture of 50% ethylene glycol and 50% water.

All data is subject to change without notice.

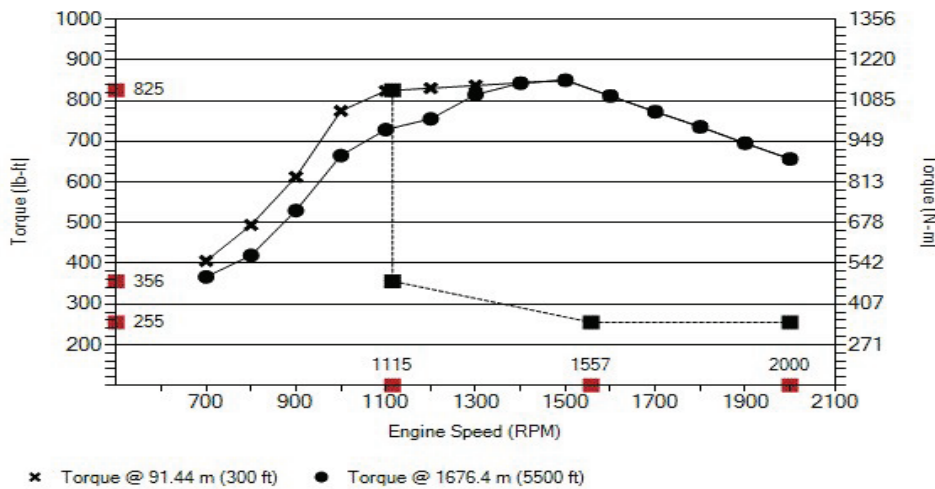

Torque Curve with NTE Zone (CEB00346)				
91.44 m (300 ft)			1676.4 mm (5500 ft)	
RPM	lb-ft	N-m	lb-ft	N-m
700	406	550	367	497
800	494	670	420	569
900	612	830	530	718
1000	774	1050	665	901
1100	824	1117	728	988
1200	830	1126	755	1023
1300	837	1135	814	1104
1400	843	1144	843	1142
1500	850	1152	850	1152
1600	811	1100	811	1100
1700	773	1048	773	1048
1800	735	997	735	997
1900	695	943	695	943
2000	657	890	657	890

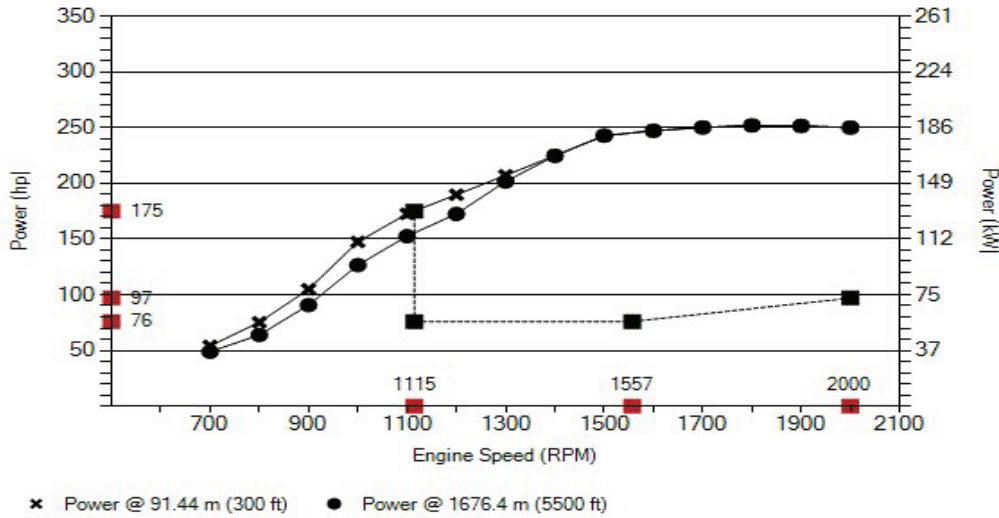

Power Curve with NTE Zone (CEB00346)				
91.44 m (300 ft)			1676.4 mm (5500 ft)	
RPM	hp	kW	hp	kW
700	54	40	49	36
800	75	56	64	48
900	105	78	91	68
1000	147	110	127	94
1100	173	129	153	114
1200	190	141	172	129
1300	207	154	202	150
1400	225	168	225	167
1500	243	181	243	181
1600	247	184	247	184
1700	250	186	250	186
1800	252	188	252	188
1900	251	188	251	188
2000	250	186	250	188

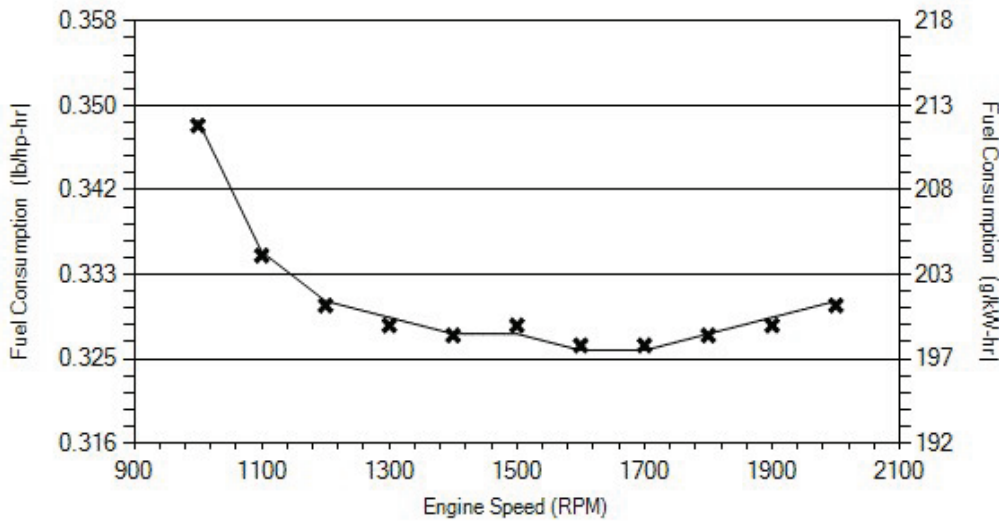

Fuel Consumption		
RPM	lb/hp-hr	g/kW-hr
1000	0.348	212
1100	0.335	204
1200	0.33	201
1300	0.328	200
1400	0.327	199
1500	0.328	199
1600	0.326	198
1700	0.326	198
1800	0.327	199
1900	0.328	200
2000	0.33	201

Curves shown above represent gross engine performance capabilities obtained and corrected in accordance with SAE J1995 conditions of 100 kPa barometric pressure [91 m (300 ft) altitude], 25 deg C (77 deg F) inlet air temperature, and 1 kPa water vapor pressure with No.2 diesel fuel.

Tolerance within +/- 5 %

Intake Air System

Maximum allowable air temperature rise over ambient at intake manifold (naturally aspirated engines) or turbo compressor inlet (turbo-charged engines): *This parameter impacts emissions, LAT, and/or altitude capability

	30.1 delta deg F	16.7 delta deg C
--	------------------	------------------

Cooling System

Maximum charge air cooler outlet to ambient at 25 deg C (77 deg F) (CAC dT)	63.0 delta deg F	35.0 delta deg C
Maximum CAC outlet temperature at less than or equal to 25 deg C (77 deg F) ambient	140 deg F	60 deg C
Maximum allowable pressure drop across charge air cooler and OEM CAC piping (IMPD)	4.0 in-Hg	13.5 kPa
Maximum coolant temperature for engine protection controls	225 deg F	107 deg C
Maximum coolant operating temperature at engine outlet (max. top tank temp)	225 deg F	107 deg C

Exhaust System

Maximum exhaust backpressure imposed by exhaust system (if DPF is present, the limit is at soot level after regeneration or cleaning)	8.9 in-Hg	30.2 kPa
---	-----------	----------

Lubrication System

Nominal operating oil pressure at minimum low idle	10.0 psi	69 kPa
Nominal operating oil pressure at maximum rated speed	55.1 psi	385 kPa
Minimum engine oil pressure at minimum low idle (for engine protection devices)	7.5 psi	52 kPa

Fuel System

*Fuel cooling requirements with diesel fuel

The maximum heat rejection to return fuel at maximum coolant and inlet fuel temperature is 0.72 kW (41 BTU / min) at a fuel return flow rate of 40 kg/hr (88 lb/hr) with a fuel return temperature of 101 deg C (213 deg F) prior to cooler.

Maximum supply fuel flow	201 lb/hr	91 kg/hr
Maximum return fuel flow	88 lb/hr	40 kg/hr
Engine fuel compatibility (consult Service Bulletin #5411406 for appropriate use of other fuels)	B20, B5, ULSD	
Maximum fuel inlet pressure	10 psi	69 kPa

Performance Data

Maximum low idle speed: 1200 RPM
 Minimum low idle speed: 700 RPM
 Maximum overspeed capability: 3750 RPM
 Maximum continuous power: 173 kW (232 hp)
 Maximum continuous speed: 2000 RPM

	Governed Power	Maximum Power	Peak Torque
Engine Speed	2200 RPM	1800 RPM	1500 RPM
Output Power	186 kW (250 hp)	188 kW (252 hp)	181 kW (243 hp)
Torque	890 N-m (657 lb-ft)	997 N-m (735 lb-ft)	1152 N-m (850 lb-ft)
Motoring Power	32 kW (42 hp)	27 kW (37 hp)	18 kW (25 hp)
Intake Manifold Pressure	145 kPa (43 in-Hg)	162 kPa (48 in-Hg)	163 kPa (48 in-Hg)
Turbo Comp. Outlet Pressure	157.5 kPa (46.6 in-Hg)	173.2 kPa (51.3 in-Hg)	171.5 kPa (50.8 in-Hg)
Turbo Comp. Outlet Temperature	152 deg C (306 deg F)	161 deg C (323 deg F)	162 deg C (324 deg F)
Inlet Air Flow	220 L/s (466 ft ³ /min)	214 L/s (454 ft ³ /min)	184 L/s (390 ft ³ /min)
Charge (Fresh Air) Flow	15.4 kg/min (34.0 lb/min)	15.0 kg/min (33.2 lb/min)	12.9 kg/min (28.5 lb/min)
Exhaust Gas Flow	464 L/s (982 ft ³ /min)	455 L/s (965 ft ³ /min)	426 L/s (902 ft ³ /min)
Exhaust Gas Temperature	490 deg C (913 deg F)	489 deg C (912 deg F)	532 deg C (990 deg F)
Heat Rejection to Coolant	75.8 kW (4308 BTU/min)	76.0 kW (4322 BTU/min)	77.9 kW (4430 BTU/min)
Heat Rejection to Ambient	21.1 kW (1200 BTU/min)	21.1 kW (1200 BTU/min)	21.1 kW (1200 BTU/min)
Heat Rejection to Exhaust	137.1 kW (7797 BTU/min)	133.0 kW (7564 BTU/min)	126.9 kW (7217 BTU/min)

*When operating Naturally Aspirated engines above SAE J1995 conditions, it should be noted that smoke levels will increase due to combustion inefficiencies associated with a reduction in the air to fuel mixture.

Cranking System (Cold Starting Capability)

Minimum cranking speed: 120 RPM

Required Starting Aids:

Intake Air Heater Required

Cold Start Demonstration Testing Data (at Sea Level)			
Cold Soak Temperature	-12 deg C (10 deg F)	-18 deg C (-0 deg F)	-32 deg C (-25 deg F)
Added OEM Parasitic Load	271 N-m (200 lb-ft)	271 N-m (200 lb-ft)	271 N-m (200 lb-ft)
Starter Motor System Voltage	24 V	24 V	24 V
Starter Motor Rating	7.8 kW	7.8 kW	7.8 kW
Lube Oil Viscosity	15W-40	5W-40	5W-40
Starter Batteries	750 CCA	750 CCA	1500 CCA
Tested Starting Aid(s), used together if multiple items are listed	Grid Heater	Grid Heater	Grid Heater
Tested Starting Aid(#2)			Coolant Heater

These simulated start results show maximum OEM parasitic load that can be applied while achieving a start with 15 seconds or less cranking time.

1. Some engines require grid heater or glow plugs as part of the required base hardware. These items will be listed if used to achieve the start shown.
2. Note that ether injection systems cannot be added on engines equipped with an intake grid heater or glow plugs.

Noise Emissions

Free field sound pressure level at 1 meter (3.28ft) at rated power (speed and load) per SAE J1074.

Top: 92.3 dB(A)

Right Side: 93.7 dB(A)

Left Side: 93.2 dB(A)

Front: 95.2 dB(A)

Extended Datasheets

1. 00084.18 Altitude Derate Curve Calculator - Industrial

Change Log

Date	Author	Description
9/16/2016 12:00:00 AM	Rajan Kalirai	Preliminary Datasheet
12/07/2016	Rajan Kalirai	Updated Rating Type
4/21/2017 12:00:00 AM	Rajan Kalirai	Updated to Beta Content
6/13/2018 12:00:00 AM	Rajan Kalirai	Added Cold Start Information

Status for curves and data: Final-(Measured Data)

Data shown is representative of engine performance. Engine to engine variability may cause deviation from reported values

Data updated by Rajan Kalirai

Bending moment diagrams may be available on GCE under Engine Specific Topics

TRAILER MOUNTED

NET WEIGHT: 4122 LBS.(1870 KG.)
SHIPPING WEIGHT: 4563 LBS.(2070 KG.)

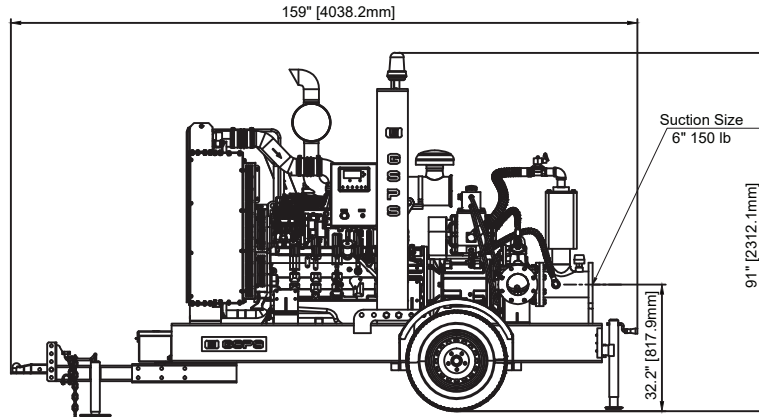
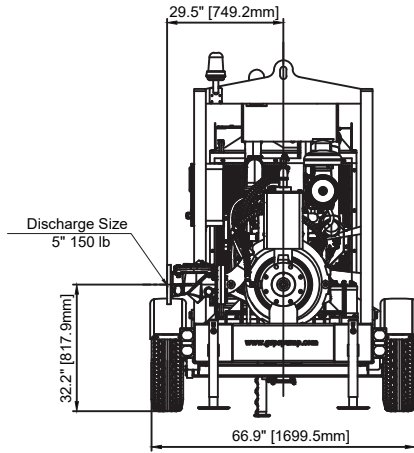

SKID MOUNTED

NET WEIGHT: 3902 LBS.(1770 KG.)
SHIPPING WEIGHT: 4343 LBS.(1970 KG.)

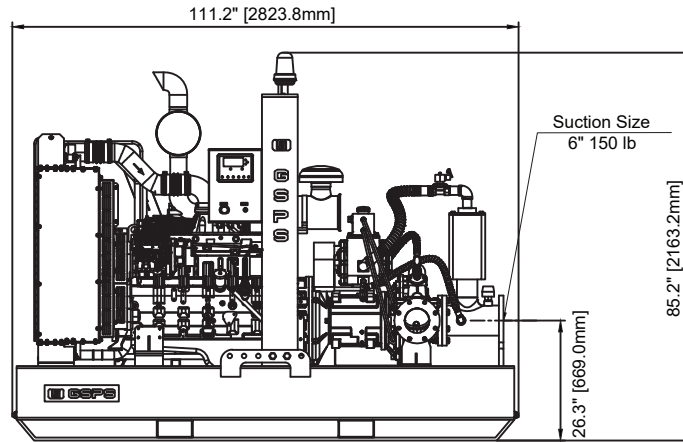
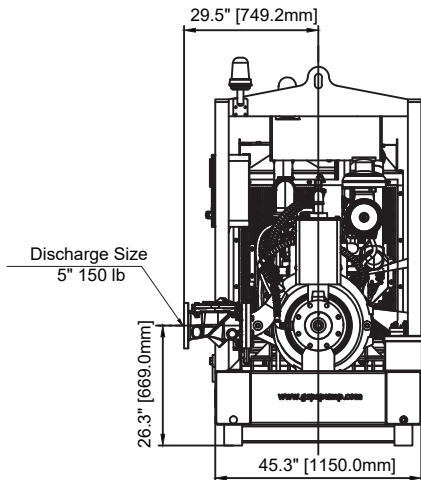

CONTACT US

📍 15405 Olde Highway 80
El Cajon, CA 92021

☎ (760) 821-8112

🌐 www.daepumps.com

✉ info@daepumps.com