

Appalachian 66-74C

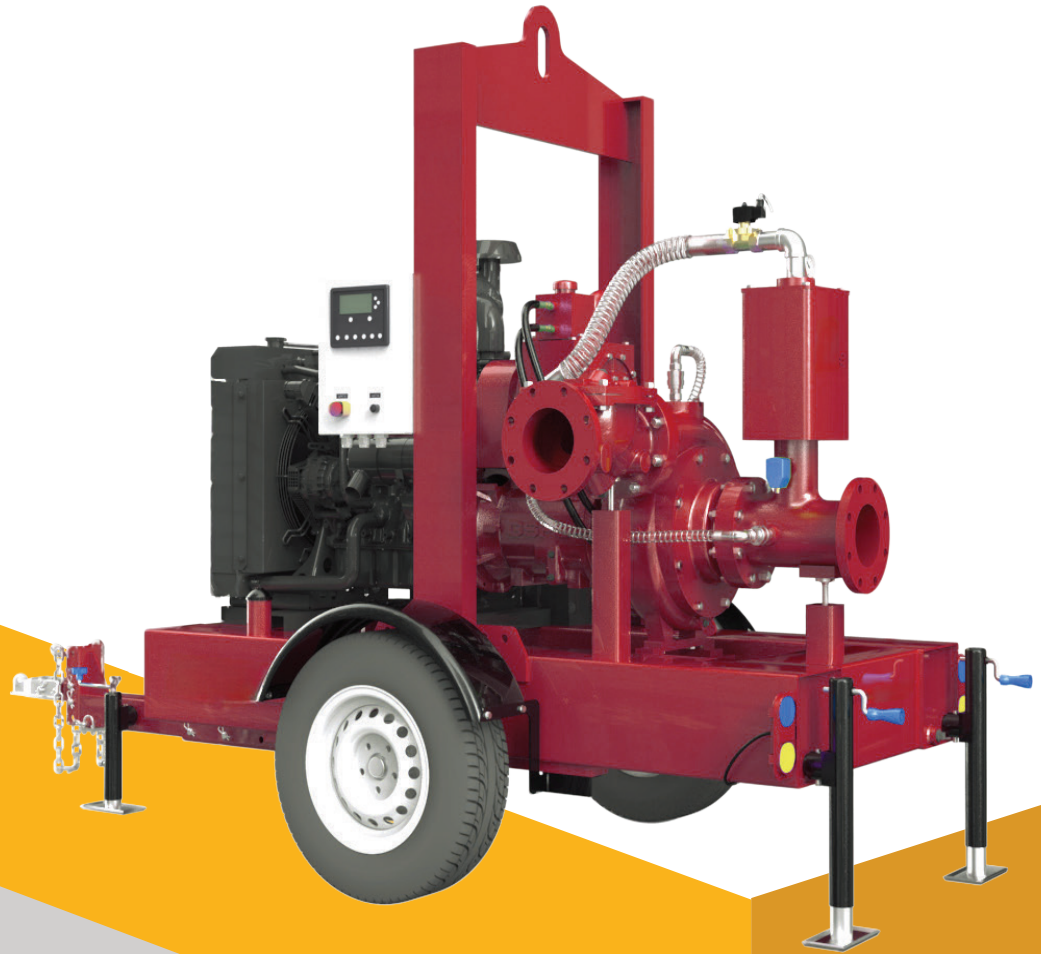

DAEPUMPS.COM

info@daepumps.com

(760) 821-8112

PUMP SPECIFICATIONS

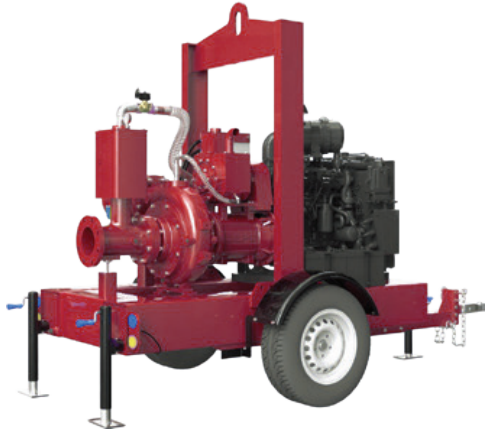

Pump End: DAE Pumps MCL-P6611S
Pump Size: 6x6 inches (150x150 mm)
Max Flow: 2900 US GPM (658 m³/h)
Max Head: 160 feet (49 m)
Solids Size: 3 inches (76 mm)
Mechanical Seal: Single mechanical seal 2.5"
Lip Seals: CR type, single lip, Buna-N (Bearing & SAE Cover) and Viton(Stuffing box)
Non-Drive End Bearing: Single row ball bearing 6314
Drive End Bearing: Duplex angular contact bearing 7316
Air/Water Chamber: Steel material and designed to separate air and water before entering into vacuum pump suction hose.
Discharge Non Return Valve: Swing type, cast iron with Buna-N disc (Viton optional)
Gasket: Aramid Fiber w/ EPDM
O Ring: Buna-N

VACUUM ASSISTED PRIMING SYSTEM

INSTANT-PRIME® SYSTEM: Patent Pending self priming pumps are equipped with the most powerful priming system and P-S-P mechanism. Instant-Prime® pump sets a new benchmark of vacuum assisted priming pumps in the industry.

VACUUM PUMP DATA*: Air Capacity: 112CFM
Vacuum: -26inHg(9m)

* at engine speed 2200 rpm

PUMP FEATURES

ECO Friendly Vacuum Priming System

DAE Pumps' EVP self priming system has extraordinary features like large air process capability, high vacuum, low operation temperature, maintenance free, oil and mechanical seal free etc.

P-S-P Auto Switch System (Prime-Sleep-Prime)

EVP system will be switched to sleep status automatically once priming was finished. When it is used for general purpose application, EVP system only operates for a few seconds for priming, which makes it almost unnecessary for daily maintenance or changing spare parts within its life cycle.

Dry Running Protection System

Instant-Prime® pumps offer three types of dry running seal options: oil reservoir lubricated mechanical seal, air cushion protected mechanical seal and grease lubricated lip seals configurations. Either of them can secure the pump run dry for a long time.

Cooling System**

A pressurized cooling flush water is introduced from centrifugal pump into vacuum pump's water jacket and then flows back to centrifugal pump. This cooling system cools the vacuum pump quickly and brings most of the heat out of the vacuum pump's cavity, and makes its rotor has an extraordinary long life.

Easy Maintenance Structure

It is very convenient to remove the vacuum pump's cover from its non-drive end, and slides can be easily pulled out for inspection or replacement. It is also easy to access to the centrifugal pump's impeller, wear ring or mechanical seal for inspection or maintenance without removing diesel engine or pump's frame since the centrifugal pump's suction cover can be fully opened.

All-In-One Pump Applications

EVP Priming system's powerful function makes Instant-Prime® pumps can be used in almost all aspects of fluid industry, including well point dewatering. Buy one pump and get all your jobs covered.

** cooling system is only needed for well point dewatering application.

APPALACHIAN 66-74C PERFORMANCE CURVE

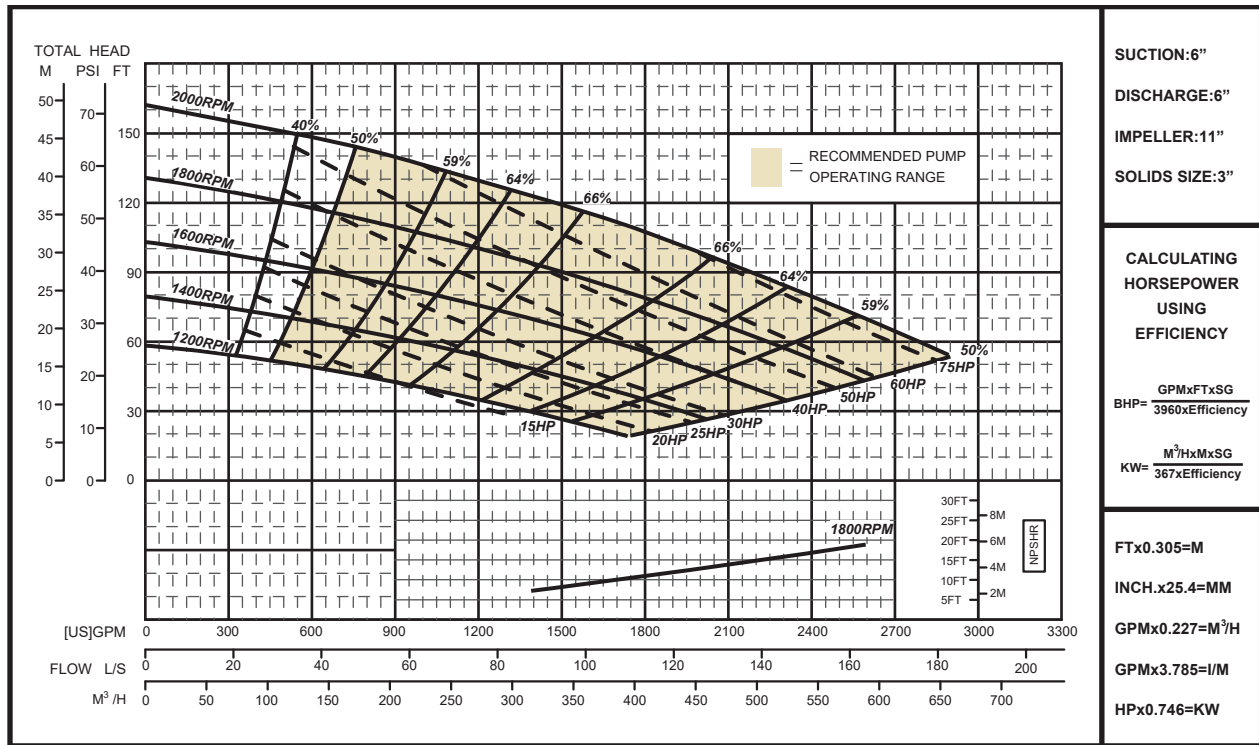

PUMP MATERIAL OF CONSTRUCTION

Main Parts	Standard (code:38)	Optional 1 (code:58)	Optional 2 (code:88)	Optional 3 (code:98)
Impeller	CA6NMSS	CA6NMSS	26% High Chrome	CD4MCu
Shaft	17-4PH	17-4PH	17-4PH	17-4PH
Wear Ring	Gray Iron	Gray Iron	Carbon Steel	316SS
Suction Cover	Gray Iron	Ductile Iron	26% High Chrome	CD4MCu
Volute	Gray Iron	Ductile Iron	26% High Chrome	CD4MCu
Stuffing Box	Gray Iron	Ductile Iron	26% High Chrome	CD4MCu
Adaptor	Ductile Iron	Ductile Iron	Ductile Iron	Ductile Iron

ENGINE SPECIFICATIONS

Engine Model: Cummins F3.8
 Rated Power At Speed: 74 HP @ 2200 RPM
 Engine Type: Turbocharged Charge Air Cooled and EGR
 Displacement: 229 cu in (3.8 Liters)
 EPA Tier: Tier 4 Final/Stage V
 Fuel Tank: 85 U.S. Gallons (320 Liters)
 Full Load Operating Time: 34.3 Hours
 Starter: 12 Volts Electric
 Control Panel: Murphy, Controls Inc, Deepsea, Kensho, Lofa

	Engine Performance Data Cummins Inc Columbus, Indiana 47202-3005 http://www.cummins.com	Industrial F3.8 FR95673	55 kW (74 hp) @ 2200 RPM 400 N-m (295 lb-ft) @ 1300 RPM		
			Configuration D0F3006CX03	CPL Code 5341	Revision 10-Jul-2023

Compression Ratio: 17.2:1	Displacement: 3.8 L (229 in 3)
Fuel System: Denso HPCR	Aspiration: Turbocharged Charge Air Cooled and EGR

Emission Certification

CARB Tier 4(f), EU Stage V, JMLIT T4f, KMOE Tier 4, US EPA Tier 4(f)

Rating Types

Continuous

All data is based upon the engine operating with fuel system, water pump, and with inlet restriction and exhaust restriction at or below datasheet limits. The alternator, fan, optional equipment, and driven components are not included. Coolant flows and heat rejection data is based on a coolant mixture of 50% ethylene glycol and 50% water.

All data is subject to change without notice.

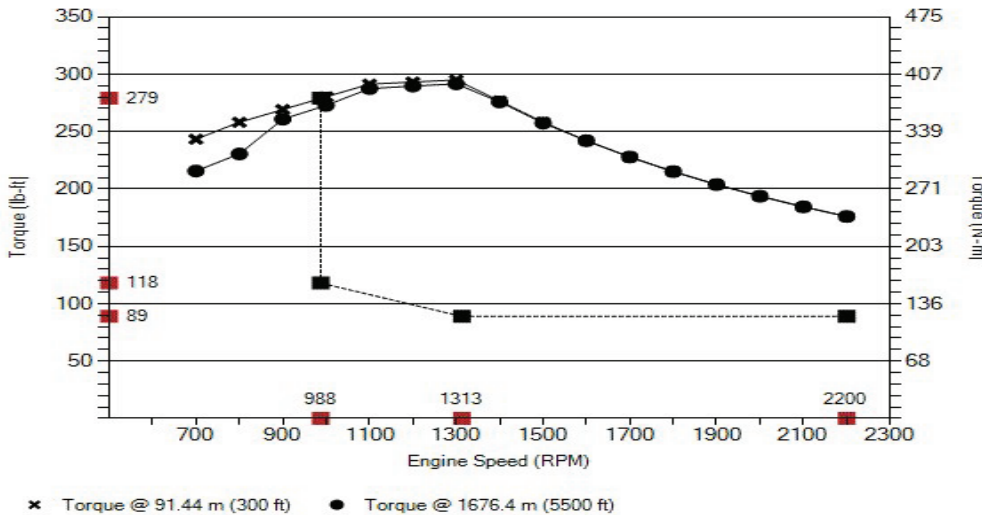

Torque Curve with NTE Zone (CEB00346)					
		91.44 m (300 ft)		1676.4 mm (5500 ft)	
RPM	lb-ft	N-m	lb-ft	N-m	
700	243	330	216	292	
800	258	350	231	313	
900	269	365	261	354	
1000	280	380	273	370	
1100	291	395	288	390	
1200	293	398	290	393	
1300	295	400	292	395	
1400	277	375	276	374	
1500	258	350	257	349	
1600	242	328	242	328	
1700	228	309	228	309	
1800	215	292	215	292	
1900	204	276	204	276	
2000	194	263	194	263	
2100	184	250	184	250	
2200	176	239	176	239	

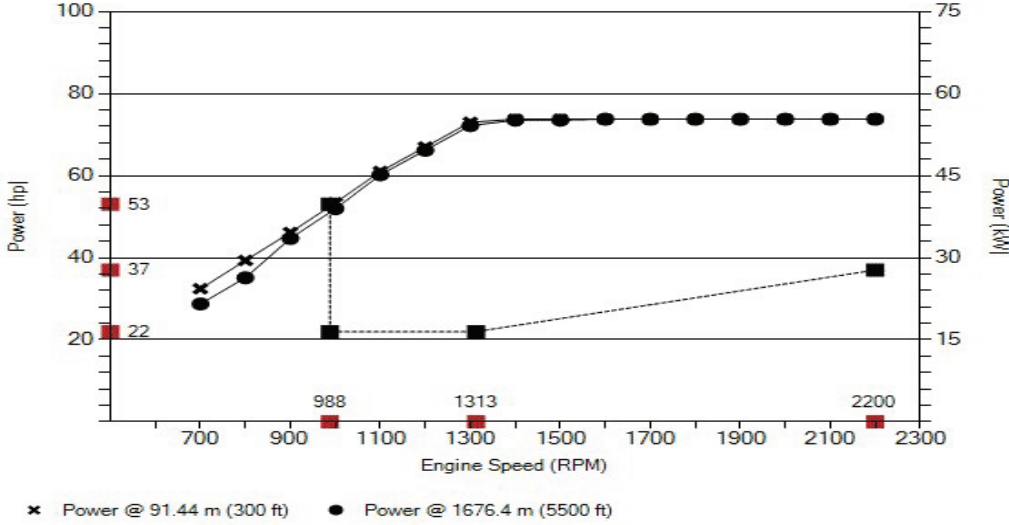

Power Curve with NTE Zone (CEB00346)				
91.44 m (300 ft)		1676.4 mm (5500 ft)		
RPM	lb-ft	N-m	lb-ft	N-m
700	32	24	29	21
800	39	29	35	26
900	46	34	45	33
1000	53	40	52	39
1100	61	46	60	45
1200	67	50	66	49
1300	73	54	72	54
1400	74	55	74	55
1500	74	55	74	55
1600	74	55	74	55
1700	74	55	74	55
1800	74	55	74	55
1900	74	55	74	55
2000	74	55	74	55
2100	74	55	74	55
2200	74	55	74	55

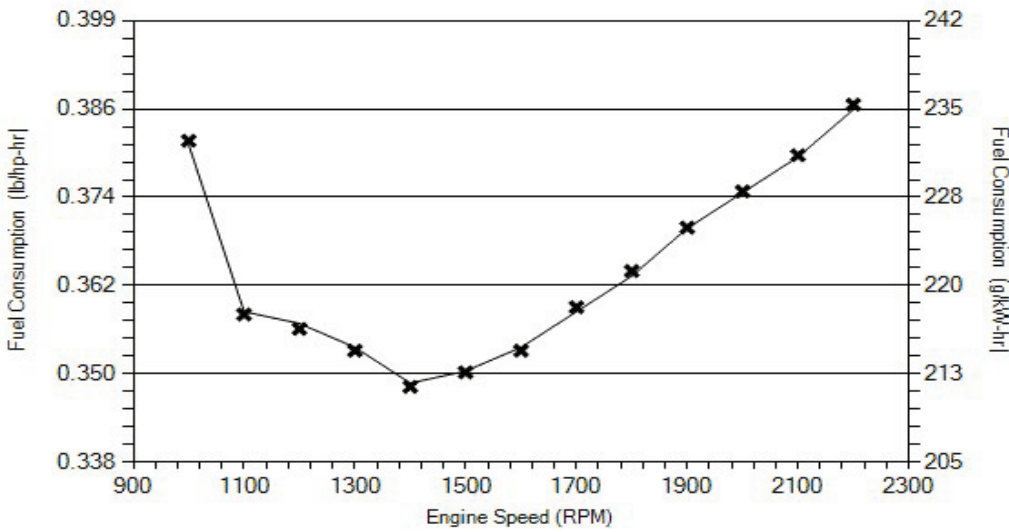

Fuel Consumption		
RPM	lb/hp-hr	g/kW-hr
1000	0.382	232
1100	0.358	218
1200	0.356	217
1300	0.353	215
1400	0.348	212
1500	0.35	213
1600	0.353	215
1700	0.359	218
1800	0.364	221
1900	0.37	225
2000	0.375	228
2100	0.38	231
2200	0.387	235

Curves shown above represent gross engine performance capabilities obtained and corrected in accordance with SAE J1995 conditions of 100 kPa barometric pressure [91 m (300 ft) altitude], 25 deg C (77 deg F) inlet air temperature, and 1 kPa water vapor pressure with No. 2 diesel fuel.

Tolerance within +/- 5%

Intake Air System

Maximum allowable air temperature rise over ambient at intake manifold (naturally aspirated engines) or turbo compressor inlet (turbo-charged engines): *This parameter impacts emissions, LAT, and/or altitude capability	30.6 delta deg F	17.0 delta deg C
--	------------------	------------------

Cooling System

Maximum charge air cooler outlet to ambient at 25 deg C (77 deg F) (CAC dT)	63.0 delta deg F	35.0 delta deg C
Maximum allowable pressure drop across charge air cooler and OEM CAC piping (IMPD)	4.0 in-Hg	13.5 kPa
Maximum coolant temperature for engine protection controls	225 deg F	107 deg C
Maximum coolant operating temperature at engine outlet (max. top tank temp)	225 deg F	107 deg C

Exhaust System

Maximum exhaust backpressure imposed by exhaust system (if DPF is present, the limit is at soot level after regeneration or cleaning)	3.6 in-Hg	12.0 kPa
Recommended exhaust pipe size (inner diameter)	3.0 in	76 mm

Lubrication System

Nominal operating oil pressure at minimum low idle	20.0 psi	138 kPa
Nominal operating oil pressure at maximum rated speed	50.0 psi	345 kPa
Minimum engine oil pressure at minimum low idle (for engine protection devices)	10.0 psi	69 kPa

Fuel System

*Fuel cooling requirements with diesel fuel

The maximum heat rejection to return fuel at maximum coolant and inlet fuel temperature is of 32 kg/hr (71 lb/hr) with a fuel return temperature of 90 deg C (194 deg F) prior to cooler.	0.39 kW (22 BTU/min) at a fuel return flow rate	
Maximum supply fuel flow	129 lb/hr	59 kg/hr
Maximum return fuel flow	71 lb/hr	32 kg/hr
Engine fuel compatibility (consult Service Bulletin #5411406 for appropriate use of other fuels)	B20, B5, ULSD	
Maximum fuel inlet pressure	3 psi	20 kPa

Performance Data

Maximum low idle speed: 1200 RPM
 Minimum low idle speed: 800 RPM
 Maximum overspeed capability: 3750 RPM

	Governed Power	Maximum Power	Peak Torque
Engine Speed	2200 RPM	1700 RPM	1300 RPM
Output Power	55 kW (74 hp)	55 kW (74 hp)	54 kW (73 hp)
Torque	239 N-m (176 lb-ft)	309 N-m (228 lb-ft)	400 N-m (295 lb-ft)
Motoring Power	17 kW (23 hp)	11 kW (14 hp)	5 kW (7 hp)
Intake Manifold Pressure	97 kPa (29 in-Hg)	93 kPa (28 in-Hg)	86 kPa (26 in-Hg)
Turbo Comp. Outlet Pressure	109.2 kPa (32.3 in-Hg)	102.0 kPa (30.2 in-Hg)	92.5 kPa (27.4 in-Hg)
Turbo Comp. Outlet Temperature	132 deg C (269 deg F)	130 deg C (266 deg F)	125 deg C (257 deg F)
Inlet Air Flow	83 L/s (176 ft3/min)	66 L/s (139 ft3/min)	56 L/s (119 ft3/min)
Charge (Fresh Air) Flow	5.7 kg/min (12.6 lb/min)	4.5 kg/min (10.0 lb/min)	3.9 kg/min (8.5 lb/min)
Exhaust Gas Flow	164 L/s (347 ft3/min)	139 L/s (295 ft3/min)	132 L/s (279 ft3/min)
Exhaust Gas Temperature	399 deg C (751 deg F)	435 deg C (815 deg F)	518 deg C (964 deg F)
Heat Rejection to Coolant	44.4 kW (2523 BTU/min)	39.7 kW (2259 BTU/min)	38.7 kW (2203 BTU/min)
Heat Rejection to Ambient	8.0 kW (455 BTU/min)	8.0 kW (455 BTU/min)	8.0 kW (455 BTU/min)
Heat Rejection to Exhaust	37.0 kW (2104 BTU/min)	32.3 kW (1835 BTU/min)	33.3 kW (1895 BTU/min)

*When operating Naturally Aspirated engines above SAE J1995 conditions, it should be noted that smoke levels will increase due to combustion inefficiencies associated with a reduction in the air to fuel mixture.

Cranking System (Cold Starting Capability)

Minimum cranking speed: 120 RPM

Required Starting Aids:

Intake Air Heater Required

Noise Emissions

Free field sound pressure level at 1 meter (3.28ft) at rated power (speed and load) per SAE J1074.

Top: 88.7 dB(A)

Right Side: 91.8 dB(A)

Left Side: 91.8 dB(A)

Front: 91.2 dB(A)

Extended Datasheets

1. 00084.18 Altitude Derate Curve Calculator - Industrial

Change Log

Date	Author	Description
1/19/2017 12:00:00 AM	Rajan Kalirai	Preliminary Datasheet
07/25/2017	Rajan Kalirai	Changed Rating Type to Continuous
8/3/2017 12:00:00 AM	Rajan Kalirai	Updated Advertised Curve

Status for curves and data: Final-(Measured data)

Data shown is representative of engine performance. Engine to engine variability may cause deviation from reported values

Data updated by Jessica A Kuehner

Bending moment diagrams may be available on GCE under Engine Specific Topics

TRAILER MOUNTED

NET WEIGHT: 3924 LBS. (1780 KG.)
SHIPPING WEIGHT: 4254 LBS. (1930 KG.)

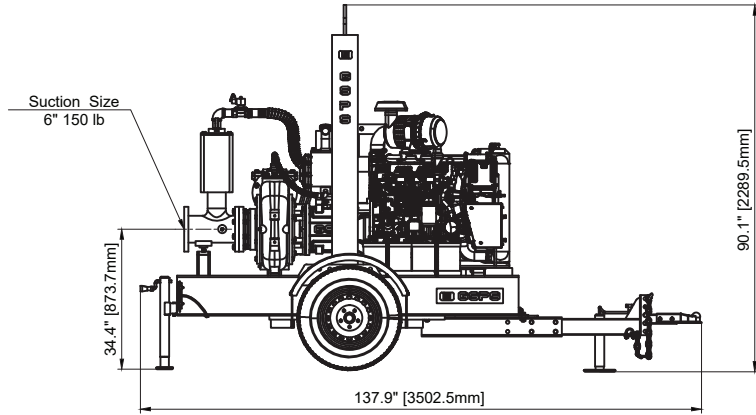
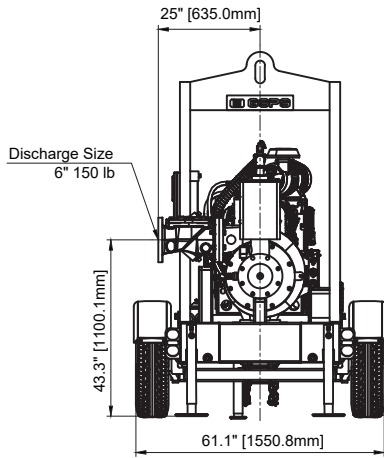

SKID MOUNTED

NET WEIGHT: 3703 LBS. (1680 KG.)
SHIPPING WEIGHT: 4034 LBS. (1830 KG.)

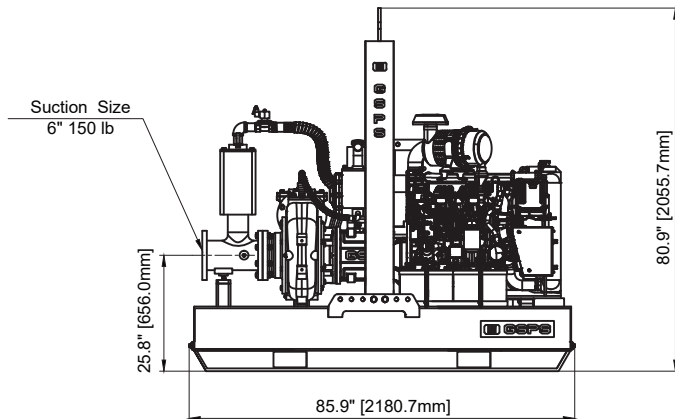
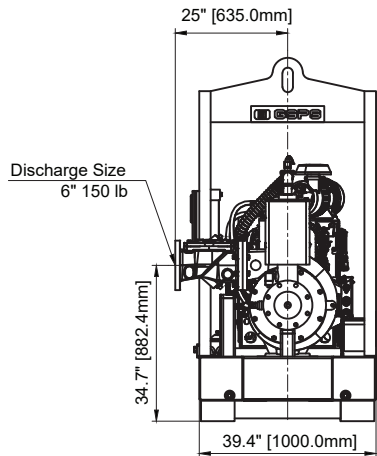

CONTACT US

📍 15405 Olde Highway 80
El Cajon, CA 92021

☎ (760) 821-8112

🌐 www.daepumps.com

✉ info@daepumps.com