

Appalachian 88-130C



DAEPUMPS.COM

info@daepumps.com

(760) 821-8112

PUMP SPECIFICATIONS



Pump End: DAE Pumps MCL-P8812S
Pump Size: 8x8 inches (200x200 mm)
Max Flow: 4500 US GPM (1025 m³/h)
Max Head: 197 feet (60 m)
Solids Size: 3 inches (76 mm)
Mechanical Seal: Single mechanical seal 2.5"
Lip Seals: CR type, single lip, Buna-N (Bearing & SAE Cover) and Viton (Stuffing box)
Non-Drive End Bearing: Single row ball bearing 6313
Drive End Bearing: Duplex angular contact bearing 6315
Air/Water Chamber: Steel material and designed to separate air and water before entering into vacuum pump suction hose.
Discharge Non Return Valve: Swing type, cast iron with Buna-N disc (Viton optional)
Gasket: Aramid Fiber w/ EPDM
O Ring: Buna-N

VACUUM ASSISTED PRIMING SYSTEM

INSTANT-PRIME® SYSTEM: Patent Pending self priming pumps are equipped with the most powerful priming system and P-S-P mechanism. Instant-Prime® pump sets a new benchmark of vacuum assisted priming pumps in the industry.

VACUUM PUMP DATA*: Air Capacity: 112CFM
Vacuum: -26inHg(9m)

* at engine speed 2200 rpm

PUMP FEATURES

ECO Friendly Vacuum Priming System

DAE Pumps' EVP self priming system has extraordinary features like large air process capability, high vacuum, low operation temperature, maintenance free, oil and mechanical seal free etc.

P-S-P Auto Switch System (Prime-Sleep-Prime)

EVP system will be switched to sleep status automatically once priming was finished. When it is used for general purpose application, EVP system only operates for a few seconds for priming, which makes it almost unnecessary for daily maintenance or changing spare parts within its life cycle.

Dry Running Protection System

Instant-Prime® pumps offer three types of dry running seal options: oil reservoir lubricated mechanical seal, air cushion protected mechanical seal and grease lubricated lip seals configurations. Either of them can secure the pump run dry for a long time.

Cooling System**

A pressurized cooling flush water is introduced from centrifugal pump into vacuum pump's water jacket and then flows back to centrifugal pump. This cooling system cools the vacuum pump quickly and brings most of the heat out of the vacuum pump's cavity, and makes its rotor has an extraordinary long life.

Easy Maintenance Structure

It is very convenient to remove the vacuum pump's cover from its non-drive end, and slides can be easily pulled out for inspection or replacement. It is also easy to access to the centrifugal pump's impeller, wear ring or mechanical seal for inspection or maintenance without removing diesel engine or pump's frame since the centrifugal pump's suction cover can be fully opened.

All-In-One Pump Applications

EVP Priming system's powerful function makes Instant-Prime® pumps can be used in almost all aspects of fluid industry, including well point dewatering. Buy one pump and get all your jobs covered.

** cooling system is only needed for well point dewatering application.

APPALACHIAN 88-130C PERFORMANCE CURVE

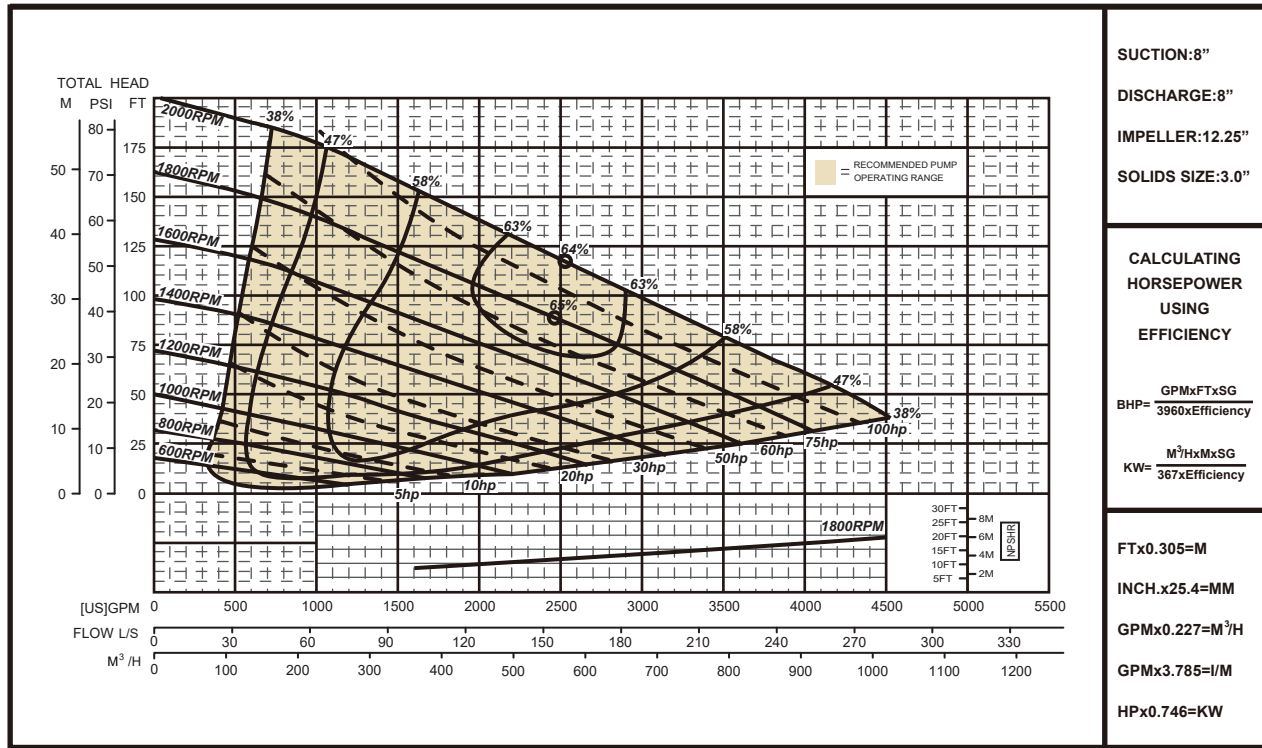

PUMP MATERIAL OF CONSTRUCTION

Main Parts	Standard (code:38)	Optional 1 (code:58)	Optional 2 (code:88)	Optional 3 (code:98)
Impeller	CA6NMSS	CA6NMSS	26% High Chrome	CD4MCu
Shaft	17-4PH	17-4PH	17-4PH	17-4PH
Wear Ring	Gray Iron	Gray Iron	Carbon Steel	316SS
Suction Cover	Gray Iron	Ductile Iron	26% High Chrome	CD4MCu
Volute	Gray Iron	Ductile Iron	26% High Chrome	CD4MCu
Stuffing Box	Gray Iron	Ductile Iron	26% High Chrome	CD4MCu
Adaptor	Ductile Iron	Ductile Iron	Ductile Iron	Ductile Iron

ENGINE SPECIFICATIONS

Engine Model: Cummins F3.8
 Rated Power At Speed: 130 HP @ 2200 RPM
 Engine Type: Turbocharged Charge Air Cooled and EGR
 Displacement: 229 cu inches (3.8 Liters)
 EPA Tier: Tier 4 Final
 Fuel Tank: 79 U.S.Gallons (300 Liters)
 Full Load Operating Time: 13.2 Hours
 Starter: 12 Volts Electric
 Control Panel: Murphy, Controls Inc, Deepsea, Kensho, Lofa

	Engine Performance Data Cummins Inc Columbus, Indiana 47202-3005 http://www.cummins.com	Industrial F3.8 FR94290	97 kW (130 hp) @ 2200 RPM 488 N-m (360 lb-ft) @ 1600 RPM
			Configuration: D0F3006CX03 CPL Code: 4142 Revision: 10-Jul-2023

Compression Ratio: 17.2:1	Displacement: 3.8 L (229 in 3)
Fuel System: Denso HPCR	Aspiration: Turbocharged Charge Air Cooled and EGR

Emission Certification

EPA/CARB Tier 4(f)

Rating Types

Intermittent

All data is based upon the engine operating with fuel system, water pump, and with inlet restriction and exhaust restriction at or below datasheet limits. The alternator, fan, optional equipment, and driven components are not included. Coolant flows and heat rejection data is based on a coolant mixture of 50% ethylene glycol and 50% water.

All data is subject to change without notice.

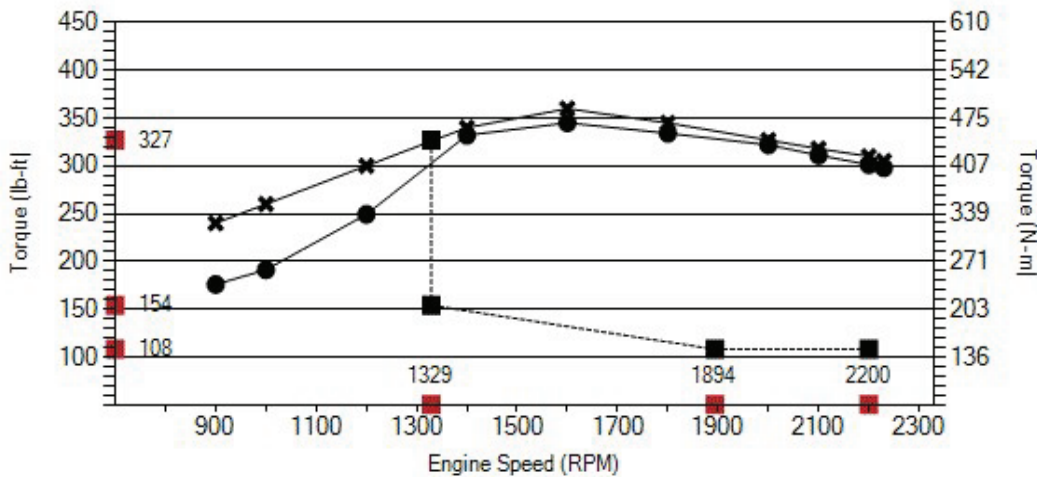

× Torque @ 91.44 m (300 ft) ● Torque @ 1676.4 m (5500 ft)

Torque Curve with NTE Zone (CEB00346)				
91.44 m (300 ft)			1676.4 mm (5500 ft)	
RPM	lb-ft	N-m	lb-ft	N-m
900	240	325	176	238
1000	260	353	191	259
1200	300	407	249	338
1400	340	461	332	450
1600	360	488	345	468
1800	345	468	334	453
2000	327	443	322	437
2100	318	431	311	422
2200	310	420	301	409
2230	305	414	298	404

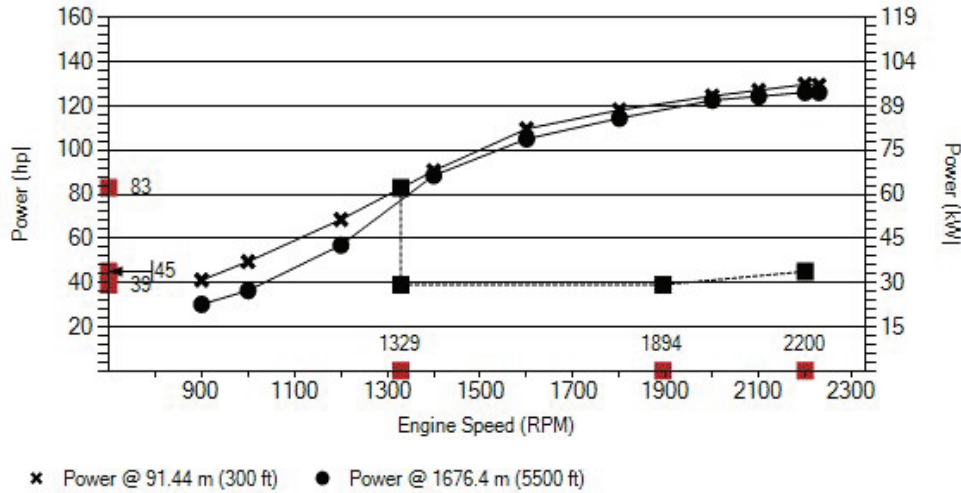

RPM	91.44m (300 ft)		1676.4m (5500 ft)	
	hp	kW	hp	kW
900	41	31	30	22
1000	50	37	36	27
1200	69	51	57	42
1400	91	68	88	66
1600	110	82	105	78
1800	118	88	114	85
2000	125	93	123	91
2100	127	95	124	93
2200	130	97	126	94
2230	129	97	126	94

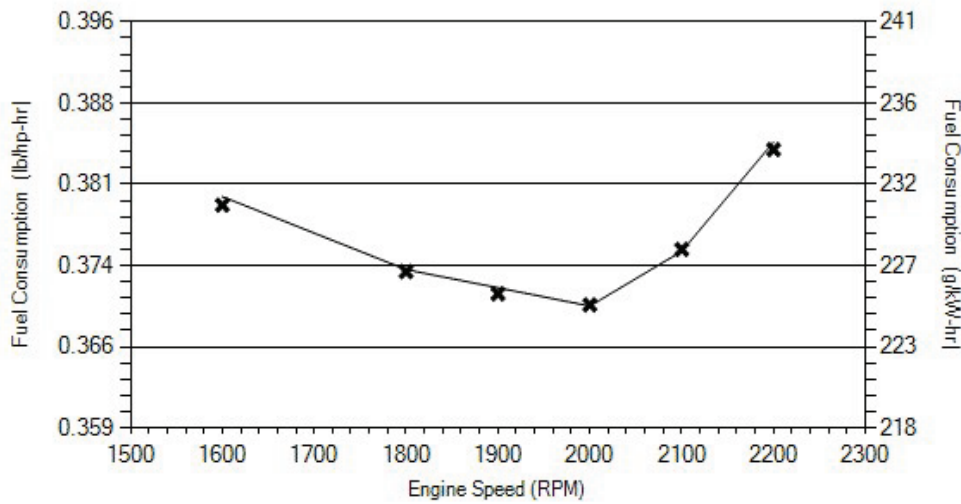

RPM	lb/hp-hr	g/kW-hr
1600	0.379	231
1800	0.373	227
1900	0.371	226
2000	0.37	225
2100	0.375	228
2200	0.384	234

Curves shown above represent gross engine performance capabilities obtained and corrected in accordance with SAE J1995 conditions of 100 kPa barometric pressure [91 m (300 ft) altitude], 25 deg C (77 deg F) inlet air temperature, and 1 kPa water vapor pressure with No. 2 diesel fuel.

Tolerance within +/- 5%

Intake Air System

Maximum allowable air temperature rise over ambient at intake manifold (naturally aspirated engines) or turbo compressor inlet (turbo-charged engines): *This parameter impacts emissions, LAT, and/or altitude capability

30.6 delta deg F

17.0 delta deg C

Cooling System

Maximum charge air cooler outlet to ambient at 25 deg C (77 deg F) (CAC dT)	63.0 delta deg F	35.0 delta deg C
Maximum allowable pressure drop across charge air cooler and OEM CAC piping (IMPD)	4.0 in-Hg	13.5 kPa
Maximum coolant temperature for engine protection controls	225 deg F	107 deg C
Maximum coolant operating temperature at engine outlet (max. top tank temp)	225 deg F	107 deg C

Exhaust System

Maximum exhaust backpressure imposed by exhaust system (if DPF is present, the limit is at soot level after regeneration or cleaning)	4.6 in-Hg	15.6 kPa
---	-----------	----------

Lubrication System

Nominal operating oil pressure at minimum low idle	20.0 psi	138 kPa
Nominal operating oil pressure at maximum rated speed	50.0 psi	345 kPa
Minimum engine oil pressure at minimum low idle (for engine protection devices)	10.0 psi	69 kPa

Fuel System

*Fuel cooling requirements with diesel fuel

The maximum heat rejection to return fuel at maximum coolant and inlet fuel temperature is of 58 kg/hr (127 lb/hr) with a fuel return temperature of 115 deg C (239 deg F) prior to cooler. 1.51 kW (86 BTU/min) at a fuel return flow rate

Maximum supply fuel flow	171 lb/hr	78 kg/hr
Maximum return fuel flow	127 lb/hr	58 kg/hr
Engine fuel compatibility (consult Service Bulletin #5411406 for appropriate use of other fuels)	B20, B5, ULSD	
Maximum fuel inlet pressure	3 psi	21 kPa

Performance Data

Maximum low idle speed: 1200 RPM
Minimum low idle speed: 900 RPM
Minimum engine speed for full load sustained operation: 1700 RPM
Maximum overspeed capability: 3250 RPM
Maximum continuous power: 84 kW (112 hp)
Maximum continuous speed: 2250 RPM

	Governed Power	Maximum Power	Peak Torque
Engine Speed	2200 RPM		1600 RPM
Output Power	97 kW (130 hp)		82 kW (110 hp)
Torque	420 N-m (310 lb-ft)		488 N-m (360 lb-ft)
Motoring Power	20 kW (27 hp)		13 kW (17 hp)
Intake Manifold Pressure	139 kPa (41 in-Hg)		135 kPa (40 in-Hg)
Turbo Comp. Outlet Pressure	149.0 kPa (44.1 in-Hg)		142.2 kPa (42.1 in-Hg)
Turbo Comp. Outlet Temperature	162 deg C (324 deg F)		162 deg C (324 deg F)
Inlet Air Flow	108 L/s (228 ft3/min)		82 L/s (174 ft3/min)
Charge (Fresh Air) Flow	9.1 kg/min (20.0 lb/min)		6.8 kg/min (15.0 lb/min)
Exhaust Gas Flow	227 L/s (480 ft3/min)		183 L/s (388 ft3/min)
Exhaust Gas Temperature	489 deg C (913 deg F)		505 deg C (941 deg F)
Heat Rejection to Coolant	64.1 kW (3644 BTU/min)		53.4 kW (3036 BTU/min)
Heat Rejection to Ambient	25.4 kW (1444 BTU/min)		21.2 kW (1207 BTU/min)
Heat Rejection to Exhaust	68.5 kW (3896 BTU/min)		54.4 kW (3092 BTU/min)

*When operating Naturally Aspirated engines above SAE J1995 conditions, it should be noted that smoke levels will increase due to combustion inefficiencies associated with a reduction in the air to fuel mixture.

Cranking System (Cold Starting Capability)

Minimum cranking speed: 120 RPM

Maximum OEM parasitic load at 10 deg F and minimum cranking speed with all required starting aids before over crank protection limits.

115 lb-ft

156 N-m

Required Starting Aids:

None

Minimum ambient temperature for unaided cold start at maximum OEM parasitic load

10.0 deg F

-12.2 deg C

Minimum ambient temperature with grid heater only at maximum OEM parasitic load

-0 deg F

-18 deg C

Minimum ambient temperature with coolant and lube heater at maximum OEM parasitic load

-10 deg F

-23 deg C

Noise Emissions

Free field sound pressure level at 1 meter (3.28ft) at rated power (speed and load) per SAE J1074.

Top: 92.3 dB(A)

Right Side: 92.8 dB(A)

Left Side: 94.0 dB(A)

Front: 94.2 dB(A)

Extended Datasheets

1. 00084.18 Altitude Derate Curve Calculator - Industrial

Change Log

Date	Author	Description
10/23/2012	Omar Al-Dimashki	Initial creation
02/06/2013	Omar Al-Dimashki	Added preliminary performance data
10/10/2013	TiegLaskowske	Some alpha-measured updates
11/05/2013	Tieg Laskowske	Updated performance data chart, lubrication system section, and fuel system section with alpha-measured values
12/06/2013	Tieg Laskowske	Updated altitude derate, fuel consumption, and cold start section.
05/09/2014	Don L Herlitz	Corrected fuel flow information
08/05/2014	Neha Deshmukh	Modified performance data chart
02/18/2015	Neha Deshmukh	Updated Torque curve data
02/25/2015	Neha Deshmukh	Updated Aided Cold start data & Min. low idle speed.
03/18/2015	Neha Deshmukh	Updated General Engine Data
10/14/2015	Neha Deshmukh	Final Datasheet

Status for curves and data: Final-(Measured data)

Data shown is representative of engine performance. Engine to engine variability may cause deviation from reported values

Data updated by Jessica A Kuehner

Bending moment diagrams may be available on GCE under Engine Specific Topics

TRAILER MOUNTED

NET WEIGHT: 4210 LBS.(1910 KG.)
SHIPPING WEIGHT: 4651 LBS.(2110 KG.)

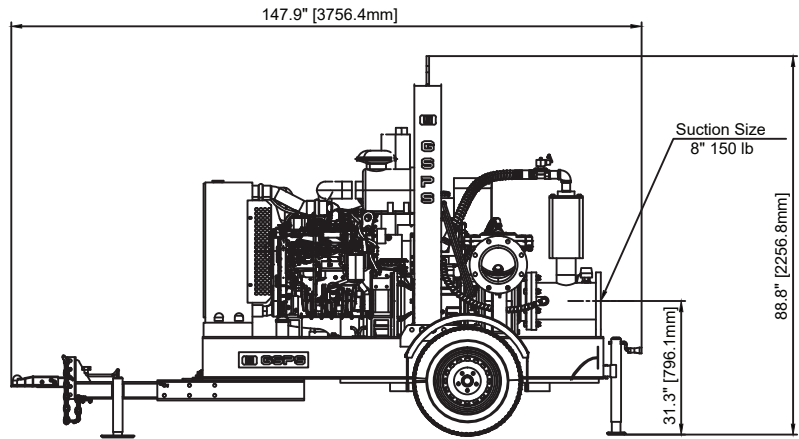
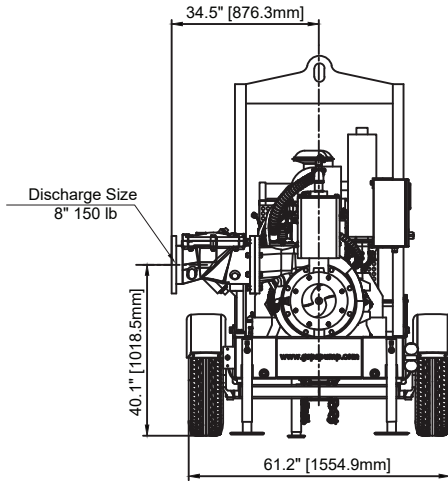

SKID MOUNTED

NET WEIGHT: 3990 LBS.(1810 KG.)
SHIPPING WEIGHT: 4323 LBS.(1960 KG.)

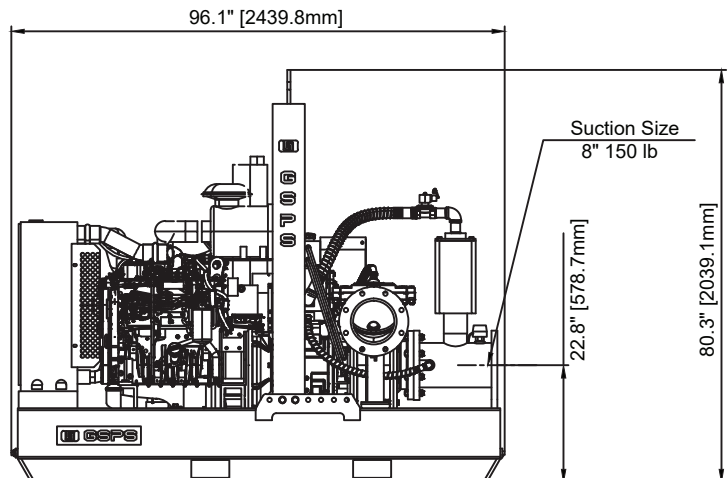
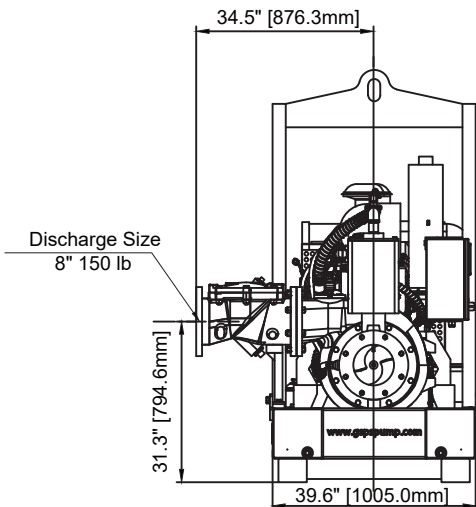

SOUND ATTENUATED

NET WEIGHT: 3719 LBS.(1687 KG.)
SHIPPING WEIGHT: 4049 LBS.(1837 KG.)

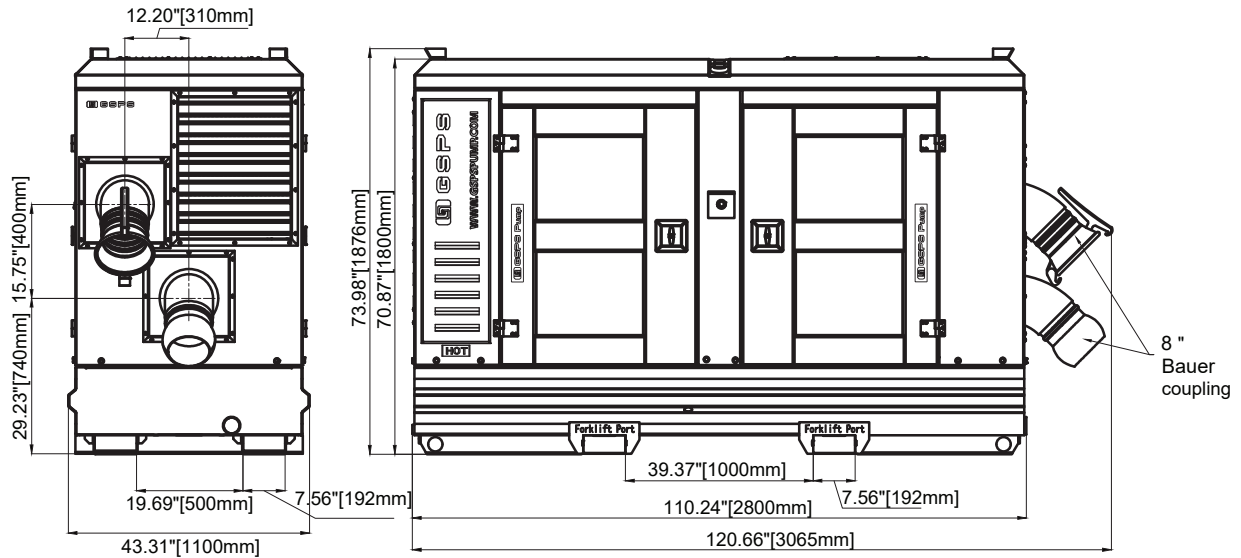

CONTACT US

📍 15405 Olde Highway 80
El Cajon, CA 92021

☎ (760) 821-8112

🌐 www.daepumps.com

✉ info@daepumps.com