

# Sonora S540

## Submersible Sludge Pumps



**DAEPUMPS.COM**

info@daepumps.com

(760) 821-8112

# Sonora S540



The **Sonora S540 Submersible Sludge Pumps** can handle thick, soft, wet mud or other similarly viscous mixtures of liquids and solids, especially the product of an industrial or refining process.

### Typical applications

- Water containing mud
- Sludge or light slurry
- Tank clean-out
- Trench and pond cleaning
- Mining

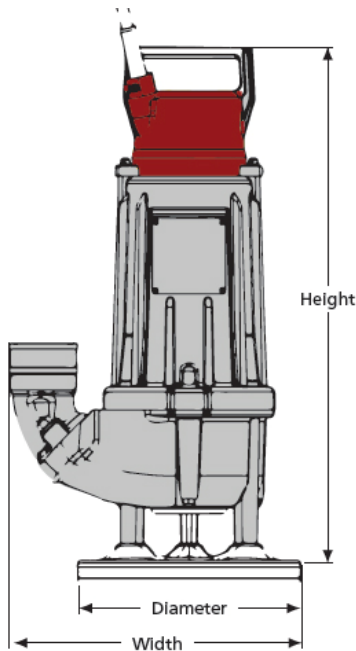

Specifications		3ph
Max. Head	Ft	92
Max. Flow	GPM	370
	M <sup>3</sup> /h	84
Rated output	HP	6.2
Max. power input	kW	7.0
Discharge connection	In	4"
Max solid handling size	In	2"

Weight & Dimensions		3ph
Weight	lbs.	130
Height	in	32
Width	in	18
Diameter	in	14

### Pump Curve

